

# Nanoconverter Architectures for 50-Year PV Systems

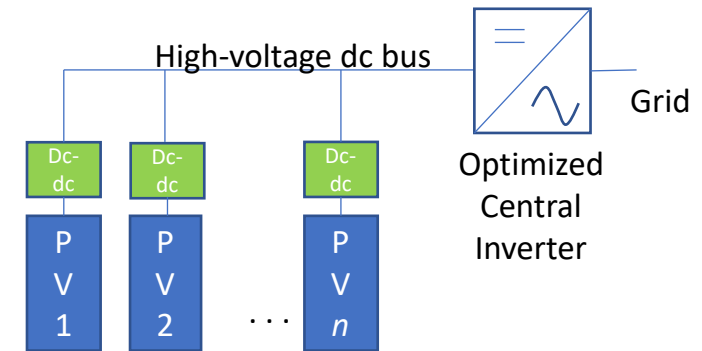
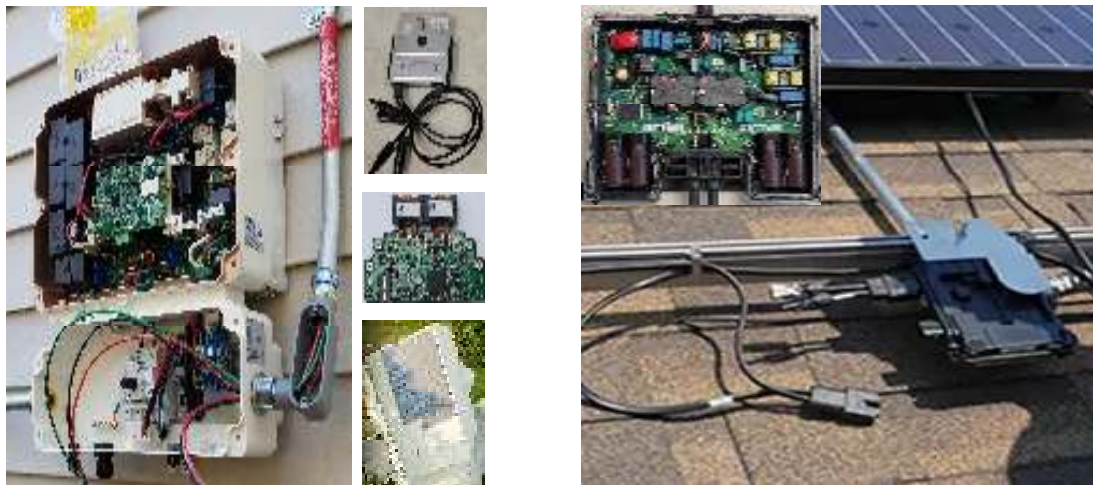

- **Problem:** Constrained choice in power architectures – central inverter, optimizers & microinverters offering some advantages/disadvantages.
- **Solution:** A two-stage architecture that achieves the best of all worlds.
- **Plan:** Develop a compact and efficient GaN-based high-voltage dc-dc converter and an optimized inverter and demonstrate a 2-3 kW system.
- **Team:** Buck Boost – RTP, NC based team of multi-disciplinary engineers passionate about green technology. Combined experience of 50+ years in power electronics and electrical engineering.
- **Network support:** Yes Solar Solutions, Transphorm (GaN) and UNCC.