

SUNSHOWER

Perovskite unlocks the potential of CPV and full-spectrum solar

Even with spectrum splitting, it's still too unstable to last the industry-standard quarter century, so who cares?

Given how incredible point I is, you just redesign the system to work with perovskite's idiosyncrasies

Its price tag makes this feasible

The solar tech curve makes it desirable

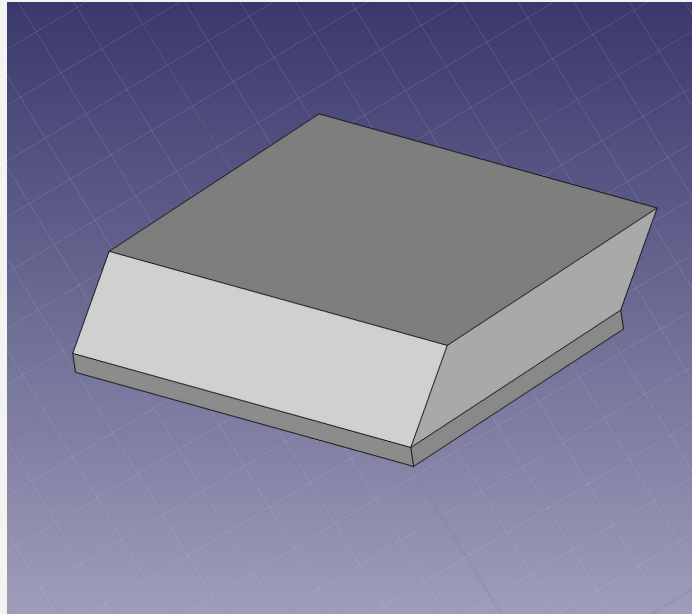

Side profile showing cell rack position within panel

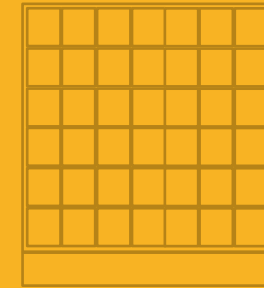

Top profile of panel showing optical regions

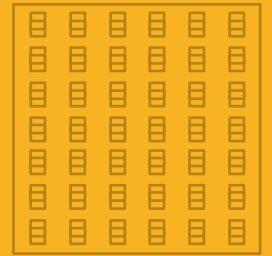

Top profile of rack showing LAMB arrays

NATE GRICE & IAN WOODS

