

2024 MARINE ENERGY COLLEGIATE COMPETITION



A Wave-Powered Autonomous Met-Ocean Sensor

Faculty Advisors:

Dr. Muhammad Hajj

Dr. Raju Datla

Graduate Student Mentors:

Ahmed Shalaby

Aspa Kokro

Undergraduate Students:

Cole Spitzner

Amira Aquarian

Katherine Petrusenko

Maribeth Seganuma

Sarah Nayema

Syed Ahmad Shah

High School Student: Hansel Carmona

Total Word Count: 18,951

Contents

1	Executive Summary	5
1.1	Our Team	5
2	Concept Overview	6
3	Relevant Stakeholders	7
4	Market Opportunity	7
4.1	Market Assessment	7
4.2	Renewable Energy Market	7
4.3	Analytics Market	8
4.4	Target Market	8
4.5	Market Strategy	8
5	Product Description	9
6	Revenue Model	9
6.1	Energy Sales	9
6.2	Data Sales	9
7	Maintenance Contracts	9
8	Marketing Strategy	10
9	Strategic Partners	10
10	Development and Operations	10
11	Financial and Benefits Analysis	11
12	Technical Design Introduction	15
13	Historical Context and Significance	17
14	Dynamics and Mathematical Modeling	17
14.1	Mathematical Model	17
14.1.1	Equation of Motion for the Pendulum	17
15	The Study of Pendulum Dynamics	18
15.1	Undamped Pendulum	18
15.2	Damped Pendulum	19
15.3	Horizontal excitation for the damped system	19
15.4	Parametric excitation for the damped system (vertical oscillation)	21
16	Pendulum in a Floating Body	22
16.1	Governing Equations of Motion	24
16.2	Angular Position and Velocity	25

17 Ocean Wave Modeling	25
17.1 Wave Forces	25
17.2 Irregular Waves Spectrum	25
18 Power Performance Analysis	26
18.1 Power Generation Under Different Sea States	27
18.1.1 Approach	27
18.1.2 Power and Frequency Calculations	28
18.1.3 Parameters Acquired for WEC Modeling	29
18.2 Results: Station 46050 in Oregon	30
18.3 Results: Station 444091 in New Jersey	32
18.4 Sea State Code by Month	33
18.5 Performance Metrics	33
18.5.1 Efficiency at Converting Energy	33
18.5.2 Reliability under Varying Operational Conditions	33
18.5.3 Scalability	34
18.6 Comparison Against Industry Standard	34
18.6.1 Cost-Competitiveness and Battery Storage	34
18.6.2 Comparison with NexSens Technology	34
19 Scaling and Power Calculations	35
19.1 Froude Similarity Analysis of a Wave Energy Converter	36
20 Reliable Data Collection and Transmission in Oceanic Environments	37
20.1 The Onboard Computer Circuit	37
20.2 Fail-System Mechanism	38
20.2.1 First Iteration	38
20.2.2 Final Iteration	38
21 Data Retrieval	39
21.1 Temperature	39
21.2 Turbidity	40
22 Data Transmission	40
23 Protection System Description	40
23.1 First Iteration	41
23.1.1 Logic	41
23.2 Second Iteration	41
23.2.1 Logic	42
23.2.2 Challenges and Improvements	42
23.3 Third Iteration	42
23.4 Results	43
24 Mooring Line Design	44
24.1 Coordinate Systems and System Parameters	44
24.2 Mathematical Modeling of Mooring Systems	45
24.3 Other Tension Factors	45

25 Mooring Line Force	46
25.1 Reducing Peak Load on the Mooring Line	46
26 Introduction to the Build and Test Challenge	47
26.1 Design Process and Material Selection	47
26.2 Sealing and Environmental Considerations	48
26.3 Assembly Considerations	49
27 Prototype Fabrication	50
27.1 Outsourcing and Manufacturing	50
27.2 Component Testing	50
27.2.1 Calibration	50
27.3 Experimental Data Collection	52
27.3.1 Initial Testing	52
28 Battery Discharge Graphs	53
28.1 Simulated Discharge	53
28.2 Observed Discharge	53
29 Energy Production	54
29.1 Assembly	57
30 Testing	59
30.1 Adjustment of Physical Properties	59
30.2 Choice of Mooring Line Material for Scaled Model Testing	60
30.3 Ease of Handling	61
30.4 Testing in Davidson Lab	62
30.5 Sensors Data for Scaled Model	63
30.6 Sensors and Calibration	63
30.7 Experimental Plan	64
30.8 Data Analysis and Results	64
31 Lessons Learnt	65
31.1 Challenges in Outsourcing	65
31.2 Insights from Environmental Considerations	65
31.3 Future Improvements	65
31.4 Project Recap and Future Considerations	65
32 Personal Statements	66
33 References	68

Business Plan Challenge

1 Executive Summary

We are a group dedicated to developing a metocean sensor powered by a pendulum-based wave energy converter (WEC), with a focus on both sustainable energy solutions and the provision of valuable oceanographic data. Our primary objective is to support research efforts related to the blue economy sector by supplying high-quality high-resolution ocean data. By integrating technology, data analytics, and community empowerment, we aim to lead the transition towards a more sustainable and informed future about ocean conditions. Our approach involves engaging with a diverse network of stakeholders, including our committed team, investors, research institutions, energy companies, and suppliers. The market opportunity for our project exists at the convergence of renewable energy and ocean data analytics services. This dual focus aligns our project with current market trends, offering a unique position for success in this burgeoning industry. Our pendulum-based WEC technology is a standout solution within the renewable energy market, providing a distinct competitive edge with its efficient energy capture and innovative design. This technology generates clean energy that is used to collect critical oceanographic and environmental data, supporting climate research and resource management. Our revenue model encompasses energy sales, data sales, and maintenance contracts. We project steady revenue growth over the next 3-5 years, driven by a combination of expanded data sales and energy contracts. By maintaining a balance between our focus on renewable energy and data analytics, we aim to diversify our income streams and establish a strong market presence. Our targeted marketing strategy includes digital marketing, industry partnerships, and educational outreach to effectively engage our audience. In addition, our commitment to quality and efficiency in development and operations, along with our financial planning and risk management strategies, position us well for long-term success. Through our innovative project, we seek to contribute to a sustainable and informed future by harnessing the power of ocean waves and providing critical data insights, while maintaining a strong focus on community engagement and environmental responsibility.

1.1 Our Team

Graduate Student Mentors

Name and Email	Responsibilities
Ahmed Shalaby (ashalab1@stevens.edu)	Team Leader, Project Manager, Documentation
Aspa Kokro (akokro@stevens.edu)	Model Testing Lead

Undergraduate Students

Name and Email	Responsibilities
Cole Spitzner (nspitzne@stevens.edu)	Technical Design and General Coordination
Amira Aquarian (aaquaria@stevens.edu)	Business Plan, Documentation and Reporting
Katherine Petrusenko (kpetruse@stevens.edu)	Mooring System and Community Outreach
Maribeth Seganuma (msuganum@stevens.edu)	Mechanical System Protection
Sarah Nayema (snayema@stevens.edu)	Power Analysis and System Integration
Syed Ahmad Shah (sshah6@stevens.edu)	Programming and Circuit Design

High School Student

Name and Email	Responsibilities
Hansel Carmona (hancar24@bergen.org)	Community Outreach, Environmental Aspects

2 Concept Overview

We are a partnership focused on developing and operating an innovative pendulum-based wave energy converter while leveraging data sales. Our primary goal is to contribute the data collected towards research, with a secondary mission to use the surplus energy to power nearby islands. With a vision to become a leading provider of renewable energy and oceanographic data services, we aim to drive the transition to a more sustainable and informed future by integrating technology, data, and community empowerment.

Last year, our team undertook a project to improve the efficiency of a pre-designed wave energy converter by the National Renewable Energy Laboratory (NREL). The original design featured a dual flap system operating out of phase to generate power. Our primary modification involved the integration of an innovative particle-damping system aimed at enhancing the power output. The experimental results were positive, confirming that within a certain range of wave amplitudes and frequencies, the flap rotation and power generation significantly increased. Additionally, there was a notable decrease in the tension within the mooring lines, which contributed to the overall stability and durability of the system.

The project taught us valuable lessons for future endeavors:

- **Early Planning:** More efficient project execution could be achieved through earlier planning stages and readiness.
- **Focus on Efficiency:** It was important to concentrate efforts on maximizing power generation efficiency to enhance the overall output of the system.
- **Cross-Disciplinary Collaboration:** Involving business students from the outset proved beneficial for developing the business plan report, ensuring the project was both technically sound and commercially viable.
- **Environmental Impact:** Greater emphasis was needed on assessing and mitigating the environmental impacts associated with deploying such technologies in marine settings.

3 Relevant Stakeholders

Our key stakeholders encompass a diverse spectrum, starting with our dedicated team members who are deeply committed to collaborative planning, research, and the successful realization of our project. Our potential investors, including research institutions and energy companies, provide crucial financial support, enabling us to achieve our objectives. Equally vital is our relationship with suppliers, as their timely and reliable provision of materials ensures the efficient manufacturing of devices pivotal to generating both data and sustainable energy. Additionally, we recognize the significance of the communities surrounding our proposed deployment site at PACWave in Oregon. Their involvement is paramount, especially considering the potential for surplus energy to benefit residents.

In addition to our dedicated team, investors, customers, and suppliers, we recognize the importance of engaging with a broader network of stakeholders. This includes government agencies and regulatory bodies responsible for marine resource management and energy regulation, academic and research institutions providing expertise and validation, industry partners and competitors for collaboration and market insights, non-governmental organizations and environmental groups concerned with marine conservation and sustainability, local communities and stakeholder groups affected by our project, and utility companies and energy grid operators for integration with existing energy infrastructure. Our proactive engagement with these stakeholders ensures regulatory compliance, environmental sustainability, community acceptance, and successful integration into existing energy systems. As part of our commitment to transparent and inclusive decision-making, we will continue to involve and communicate with these stakeholders throughout our project actively.

4 Market Opportunity

4.1 Market Assessment

The market opportunity for our project lies at the intersection of renewable energy solutions and data analytics services, both experiencing significant growth due to environmental concerns and the demand for sustainable energy sources. Our project focuses primarily on providing valuable oceanic wave data to researchers through our innovative pendulum-based wave energy converter (WEC) project. However, we also remain committed to supplying clean energy to interested parties. This dual approach aligns our project with current market trends, as our data market offers fewer competitors and exponential growth potential. Our location near PAC-Wave positions us in the same area as our main competitor, SOFAR Ocean, which runs the Spotted Platform program. This strategic focus on both data and energy uniquely positions us for success in this burgeoning industry.

4.2 Renewable Energy Market

The global renewable energy market is experiencing steady growth, fueled by a global shift towards cleaner and more sustainable energy sources. Notably, wave energy has emerged as a focal point due to its consistent availability and minimal environmental footprint. Governments and organizations worldwide are increasingly investing in renewable energy projects to curb carbon emissions and meet sustainability targets, with wave energy positioned as a promising frontier in this endeavor. Despite growing competition in the renewable energy sector, our pendulum-based WEC design stands out, offering a distinct competitive edge with its unique approach and innovative technology.

4.3 Analytics Market

The data analytics market is witnessing rapid expansion as businesses and research institutions increasingly aim to derive actionable insights from vast datasets. Particularly, oceanographic and environmental data hold immense significance for climate research, resource management, and disaster prevention efforts. With the demand for reliable ocean wave data and energy production data on the rise, specialized oceanographic data services are becoming increasingly vital. While competition in the broader data analytics sector is fierce, the niche specialization in oceanographic data services presents a distinct opportunity for differentiation, allowing for tailored solutions to meet the specific needs of clients in this critical field.

4.4 Target Market

Given our product offering, we will primarily target two customer segments:

1. **Renewable Energy Sector:** In the renewable energy sector, our primary customer segments include utilities, industrial facilities, and coastal communities. Utilities, both public and private, are seeking to diversify their energy sources and fulfill renewable energy targets, presenting a significant market opportunity. Additionally, energy-intensive industries are increasingly interested in reducing their carbon footprint and operational costs by integrating renewable energy solutions into their operations. Moreover, coastal communities with a high potential for wave energy production are keen on generating clean energy locally, aligning with our offerings and objectives. By targeting these customer segments, we aim to address a diverse range of needs and contribute to the widespread adoption of sustainable energy solutions.
2. **Oceanographic and Environmental Research Institutions:** Our secondary customer segment comprises oceanographic and environmental research institutions, including universities and research centers, government agencies, and environmental consultants. Academic institutions and research centers engaged in oceanography, climate research, and environmental studies rely heavily on high-quality data to advance scientific understanding and inform policy decisions. Government agencies responsible for monitoring and managing marine ecosystems, coastal infrastructure, and disaster preparedness also depend on accurate and comprehensive data sets. Furthermore, environmental consultants play a crucial role in providing environmental impact assessments and data for coastal development projects, requiring reliable oceanographic data and insights. By catering to the needs of these specialized customers, we aim to support critical research efforts, enhance environmental monitoring and management, and facilitate sustainable coastal development initiatives.

4.5 Market Strategy

Our marketing strategy will employ various approaches to reach our target audience effectively. Firstly, we'll utilize digital marketing tactics, optimizing our online presence through website enhancements, content marketing, and engaging social media campaigns to expand our reach within the renewable energy and data analytics sectors. Secondly, we'll foster industry partnerships with renewable energy associations, research institutions, and environmental organizations to build credibility and access potential customers. Thirdly, educational outreach efforts such as workshops, webinars, and seminars will be conducted to inform potential clients about the advantages of our technology and data services. Lastly, we'll emphasize tailored solutions, customizing our offerings to meet the specific needs of different customer segments, and highlighting the value of our

pendulum-based WEC and precise oceanographic data. Through strategic targeting of these markets, we aim to establish our business as a leading provider of sustainable energy solutions and invaluable oceanographic insights, driving sustained growth and long-term success.

5 Product Description

Pendulum-Based Wave Energy Converter (WEC) Our Pendulum-Based Wave Energy Converter (WEC) leverages the dynamic forces of ocean waves to generate renewable energy in an efficient and eco-friendly manner. Central to our WEC is a uniquely designed pendulum system, optimized to capture wave energy. This innovative feature is efficient, and reliable and promotes environmental sustainability by offering a clean energy alternative that reduces carbon emissions. The versatility of our WEC is one of its key strengths—it can be scaled to fit various project sizes, making it suitable for everything from large utility projects to smaller, community-driven installations in coastal areas. Additionally, our WEC integrates multiple sensors to collect various oceanographic and environmental data. The dual capability of renewable energy production and data collection allows our WEC to serve as a comprehensive solution for sustainable energy and supports both scientific research and responsible environmental management.

6 Revenue Model

6.1 Energy Sales

Our revenue model primarily revolves around selling the electricity generated by our pendulum-based WEC, ensuring competitive pricing for a range of customer segments. This includes utilities, both public and private, aiming to diversify energy sources and meet renewable energy targets, as well as energy-intensive industries seeking to lower carbon footprints and operational costs through renewable solutions. Additionally, we cater to coastal communities with high potential for local wave energy production, enabling them to access clean energy sources sustainably.

6.2 Data Sales

Alongside energy sales, we capitalize on the data generated by our WEC's sensors through a structured data sales strategy. This strategy includes offering subscription plans tailored for research institutions, government agencies, and environmental consultants, granting access to both real-time and historical oceanographic and environmental data. Additionally, we provide the flexibility of one-time data purchases for specific datasets or customized reports. Moreover, we offer value-added services such as data analysis, visualization, and integration to fulfill specific customer requirements, enhancing the utility and applicability of the data we provide.

7 Maintenance Contracts

To maintain the peak performance of our WECs, we provide maintenance contracts to our energy customers. These contracts encompass routine inspections, repairs, and technical assistance, constituting a supplementary source of recurring revenue. By leveraging this enhanced revenue model, we harness both the energy generation and data analytics facets of our business, diversifying our income streams and fortifying long-term profitability.

8 Marketing Strategy

Our targeted marketing strategy is designed to effectively engage our audience through various channels. This includes leveraging digital marketing to raise awareness and generate leads within the renewable energy and data analytics sectors. Additionally, we prioritize building industry partnerships with renewable energy associations, research institutions, and environmental organizations to bolster credibility and broaden our reach. Educational outreach efforts, such as workshops, webinars, and seminars, are employed to educate potential clients about the advantages of our technology and data services. Moreover, we tailor our messaging to address the unique needs and challenges of each target market segment, ensuring our marketing materials resonate effectively.

9 Strategic Partners

Our project has greatly benefited from strategic collaborations with several institutions. The University of Michigan played a pivotal role in aiding our team with generator decisions and providing technical expertise and guidance. We collaborated closely with the marine and offshore departments of the ABS Group, leveraging their experience to enhance our project's structural integrity and safety standards. The Department of Energy (DOE) supported us with project funding, enabling us to advance our wave energy technology. At Pacific Northwest National Laboratory (PNNL), we partnered with the Tethys team, which specializes in designing and producing mooring lines for wave converters, ensuring the stability and longevity of our systems. Additionally, Aceton offered its expertise in interface and force measurement solutions, providing valuable data and insights for our project. These collaborations have been instrumental in ensuring the success of our project, bringing together diverse expertise to drive innovation and achieve our goals.

10 Development and Operations

In our development and operations strategy, we prioritize efficiency and quality across all stages. We plan to manufacture, install, and maintain our pendulum-based WECs with utmost care and attention to detail. Our manufacturing system will encompass the creation of WEC products and assembly processes, ensuring the highest standards of quality are met. Installation procedures will be meticulously followed, with regular follow-ups to uphold rigorous quality standards. Regarding data collection, our team will devise comprehensive strategies for sensor deployment, maintenance, and calibration to ensure accurate and reliable data collection. We will implement secure data storage solutions to protect valuable datasets, utilizing advanced analytics tools to extract actionable insights. Our operational plan emphasizes the efficient production and deployment of WECs, detailed manufacturing processes, meticulous installation procedures, and rigorous quality control measures to guarantee reliability and performance. Additionally, we are dedicated to accurate data collection and management, deploying sensors strategically, ensuring data security, and leveraging analytics to derive meaningful insights. In manufacturing, we prioritize using high-quality, corrosion-resistant materials to construct our pendulum-based wave energy converters (WECs). We aim to minimize the carbon footprint of our production processes and leverage partnerships with local suppliers to reduce transportation-related emissions and support the regional economy. A streamlined assembly process will focus on efficiency and quality control, with an emphasis on cost-effective production and scalability. For deployment, we aim to partner with specialized marine engineering companies to ensure precise installation and anchoring of our WEC systems. These partnerships will bring in expertise and experience in marine environments, enhancing the relia-

bility and safety of our installations. To manage manufacturing and deployment risks, we plan to implement comprehensive project management strategies, including contingency planning, resource allocation, and regular progress tracking. We will also conduct thorough risk assessments to identify potential challenges early and develop mitigation plans. One potential technical barrier to implementation is the harsh marine environment, which can cause wear and tear on equipment. We will counter this with robust engineering designs and regular maintenance schedules. Additionally, our WEC systems must be compatible with existing grid infrastructure, requiring careful planning and coordination with local utilities. From a regulatory perspective, we must navigate complex permitting processes and adhere to stringent environmental regulations. We are committed to working closely with regulatory bodies to ensure our operations comply with local and international laws. Socially and environmentally, our project offers opportunities to engage with local communities and contribute to sustainable economic development. We aim to minimize environmental impact by conducting environmental impact assessments and working with stakeholders to protect marine habitats and ecosystems. Our WEC systems will follow a structured operations and maintenance schedule, with routine inspections, cleaning, and repairs as needed. We will use predictive maintenance techniques, such as data-driven analytics, to anticipate potential issues and address them before they become critical. Our operations will involve regular monitoring and adjustments to optimize performance, while our maintenance plans will focus on extending the lifespan of our equipment and minimizing downtime. In comparison to traditional power sources like diesel generators, our WEC systems offer the advantage of lower operational costs, reduced carbon emissions, and minimal noise pollution. Additionally, our systems require less frequent maintenance and have a smaller environmental footprint than cable-based installations. Our project has greatly benefited from strategic collaborations with several institutions. The University of Michigan played a pivotal role in aiding our team with generator decisions and providing technical expertise and guidance. We collaborated closely with the marine and offshore departments of the ABS Group, leveraging their experience to enhance our project's structural integrity and safety standards. The Department of Energy (DOE) supported us with project funding, enabling us to advance our wave energy technology. At Pacific Northwest National Laboratory (PNNL), we partnered with the Tethys team, which specializes in designing and producing mooring lines for wave converters, ensuring the stability and longevity of our systems. Additionally, Aceton offered its expertise in interface and force measurement solutions, providing valuable data and insights for our project. These collaborations have been instrumental in ensuring the success of our project, bringing together diverse expertise to drive innovation and achieve our goals.

11 Financial and Benefits Analysis

Our renewable energy project presents a compelling investment opportunity due to its promising financial projections, comprehensive benefits analysis, and commitment to sustainability. We anticipate a projected revenue of \$2.5 million in Year 1, primarily from energy sales and initial data subscriptions, with a steady annual increase of 12% in Years 2-3 driven by expanded data sales and additional energy contracts. By Years 4-5, we expect further growth as we secure larger energy contracts and data service subscriptions, establishing a strong market presence. Operating expenses, including manufacturing, operations and maintenance (O&M), marketing, and personnel costs, are expected to align with revenue growth.

Our initial capital investment of \$10 million will cover research, development, manufacturing setup, and initial project deployment, sourced from venture capitalists, government grants, and private investors. Potential risks such as technical, market, and regulatory challenges will be mitigated

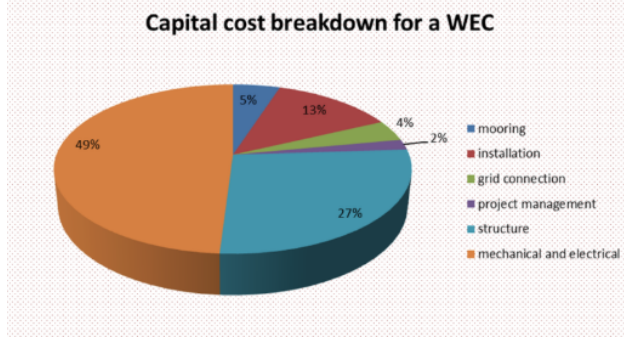

Figure 1: Capital Cost Breakdown of Wave Energy Converters.” ResearchGate, Alexander Hugues-Dit-Ciles, 26 Sept. 2015 [9]

through rigorous testing, redundancy measures, diversification of revenue streams, and adaptability to changing market conditions. Compliance with environmental regulations and protection of intellectual property associated with our technology are integral to our strategy.

In addition to our financial projections, a comprehensive Levelized Cost of Energy (LCOE) report assesses the long-term viability and competitiveness of our project, based on assumptions about project characteristics, costs, energy production, and electricity prices. The project has a capacity of 1 MW, a 25-year lifespan, and a discount rate of 7%. Construction and installation costs total \$10 million, financed over a 10-year term with a 5% interest rate. O&M costs are estimated at \$100,000 annually, and a capacity factor of 35% with an average electricity price of \$0.10 per kWh reflects market conditions.

Our project’s environmental benefits, including reduced carbon emissions and minimized harm to marine ecosystems, align with our commitment to sustainability and social responsibility. Social benefits include job creation and enhanced energy independence. We have a scalability plan that involves expanding the prototype, partnering with other companies, and entering new markets and contracts. As we achieve our growth objectives, we anticipate potential exit strategies such as acquisition or strategic partnerships with larger renewable energy or data services companies.

In summary, our comprehensive approach, financial strategy, and commitment to sustainability emphasize the significant potential and broader impact of our renewable energy project.

The estimated cost for a single prototype is stated above. If the project was scaled up, to hundreds of prototypes being produced, the overall cost would significantly decrease.

Year one expenses (including labor and material costs) = \$195,175

LCOE Calculation

The LCOE can be calculated using the following formula:

$$\text{LCOE} = \frac{\text{Total Costs}}{\text{Total Energy Produced}} \times (1 + \text{Discount Rate})^n \quad (1)$$

Where:

- Total Costs = Capital Costs + Present Value of OM Costs

Material	Cost (\$)
Hull	1,650
Pendulum	150
Shaft	95
PC Plate	75
Connectors, Bolts, Nuts, Mooring lines	778
Sealing Sheets	374
Acrylic Top Lid	483
Circuit (Arduino, Batteries, Sensors, Wires, PC-Board)	350
Shipping	1,500
Total Estimated Material Cost	5,455

Table 1: Estimated Material Cost For One Prototype

Item	Estimated Cost (\$)
Research and Development	500,000
Materials	1,000,000
Fabrication	500,000
Testing and Deployment	500,000
Particle Damping System Design/Build	500,000
Mooring Line Design/Manufacturing	250,000
Maintenance	100,000/year
Management and Permits	300,000
Total Cost	3.65 million

Table 2: Estimated Project Costs for the full scale

Description	Details
Employees	9
Hours worked per year per employee (Year 1)	1,360
Hours worked per year per employee (other years)	960
Rate per hour (\$)	15.50
Total Labor Cost (Year 1)	\$189,720
Total Cost of Labor (future years)	\$133,920

Table 3: Estimated Labor Costs

Year	2024	2025	2026	2027	2028	2029
Yearly Clients	10	20	30	40	50	60
Yearly Revenue (\$)	200,000	400,000	600,000	800,000	1,000,000	1,200,000
Cost of Goods and Services (\$)	224,784.14	159,400	159,400	159,400	159,400	159,400
Profit (\$)	-24,784.14	240,600	440,600	640,600	840,600	1,040,600

Table 4: Valuation Calculations

- Total Energy Produced = Annual Energy Production \times Project Lifespan
- n = Number of years

Total Costs

- Capital Costs = \$10,000,000
- Present Value of OM Costs (PVOM) is calculated as the present value of the operational and maintenance costs over the project lifespan.

Technical Design Challenge

12 Technical Design Introduction

Described herein is a wave-powered autonomous Met-Ocean sensor with a horizontal pendulum that reacts to wave excitation to provide energy for onboard sensors and communication equipment. The device demonstrates the power of self-sustaining data collection in marine settings. This proof of concept shows that data can be collected anywhere in the ocean with minimal cost or environmental impact. Most real-world Wave Energy Converters (WECs) designed for remote autonomous sensing will likely cost hundreds of thousands of dollars. The team strives to keep this WEC sensor well under \$100,000 to be marketed as a low-cost option, with a high variety of use cases **10**



Figure 2: Design Concept of WEC: A Hemisphere with Rotating Pendulum, Source: **1**

Sustainability and potential positive environmental impacts were prioritized for the device. Since wave energy is a clean energy source, the device produces no atmospheric pollution. Additionally, environmentally friendly materials and colors were used to minimize the impact on marine life. Stainless steel as the primary material promises durability and resilience, reducing the likelihood of needing replacements due to failure or corrosion. It also ensures recyclability for the majority of the parts when they are eventually salvaged at the end of the product's life. While the scaled-down prototype included a clear acrylic top dome, the full-scale product would utilize a white top hull with spikes to discourage birds from landing on and interfering with the device.

The primary objective of the project is to design and construct a Wave Energy Converter (WEC) that powers onboard sensors. The primary function of the device is to gather data and relay it back to a data center, with power generation requirements focused solely on providing sufficient power to the sensors, computer, and communication equipment. Additionally, energy storage was incorporated through batteries, enabling the system to function consistently despite varying power generation due to changing wave conditions. This ensures that during periods with little or no waves, the device can still collect and relay data. To prevent scope creep, the selected sensors were limited to temperature and turbidity. Consequently, the WEC required only minimal power for the sensors, facilitating a compact and space-efficient design. Electrical engineering analysis indicates that the maximum voltage and current for the scaled prototype are 12 V and 140 mA, respectively, resulting in a power consumption of 1.68 W, which aligns with the low power requirements. Another goal was to make the device straightforward to implement using affordable components, which also

facilitated easier and more accurate prototyping.

In a future market-ready iteration of the device, a broader array of sensors will be selected for the WEC to enhance the scope and utility of data collection. If this increases power demands, the device will incorporate integrated solar panels and wind turbine technology to cover the resulting power deficit. For the purposes of the MECC challenge, wave energy will constitute at least 51% of the power generation if other methods are added. These additional clean energy sources would require only marginally more starting materials to construct and would integrate seamlessly into the device's physical and electrical infrastructure.

In a recent study, X. Jiang et al. **10** introduced an innovative conceptual model of a Wave Energy Converter (WEC) with a pendulum operating in the horizontal plane, referred to as the Vertical Axis Parametric Pendulum Wave Energy Converter (VAPPWEC) **10**. The authors conducted a comprehensive analysis of the system's performance under various wave conditions. Their model test also identified the parametric resonance zone of the pendulum and demonstrated how to optimize power generation accordingly. The primary insight gained from this paper was the design of a WEC with an enclosed pendulum rotating in the horizontal plane, as depicted in Figure 1. This inspired the Stevens team in their pursuit of a mechanism capable of generating energy while accommodating the necessary sensors.

Furthermore, the development of both technical and soft skills among the team members was considered a natural and necessary aspect of our project. Participation in the competition introduced members to the field of marine energy. The webinars and information sessions hosted by the MECC operators exposed members to the diverse and important work being conducted in the field. Although much of the technical expertise and advanced knowledge is challenging to glean from these online sessions, the team believes that significant growth arises from simply listening to the conversations occurring in the field. The understanding gained from exposing the team to these real-life discussions on the various types of WECs, the current state and future of marine energy, safety and sustainability within marine energy, and more, is invaluable.

The team's WEC-powered sensor holds significant promise for societal advancement, particularly in remote regions and coastal communities where access to power and accurate data is limited yet critical. By harnessing the renewable energy of ocean waves, the team's device offers a sustainable solution for powering essential operations such as weather monitoring and communication, thereby enhancing the resilience of remote islands and coastal areas. Moreover, the real-time data collected by the sensors enhances our ability to forecast weather patterns, monitor tides, and predict hurricanes, thereby bolstering disaster preparedness and safeguarding coastal populations and marine ecosystems. The team aims not only to advance the field of marine energy but also to address pressing societal needs, ultimately contributing to the creation of more resilient and sustainable communities worldwide.

Horizontal pendulum based wave energy converters (PWECs) utilize the oscillatory motion of ocean waves to induce mechanical movements in a pendulum system, which in turn drives a generator to produce electricity **??**. This technology capitalizes on the simplicity of mechanical movements and the abundance of ocean wave energy, presenting a sustainable solution to renewable energy generation.

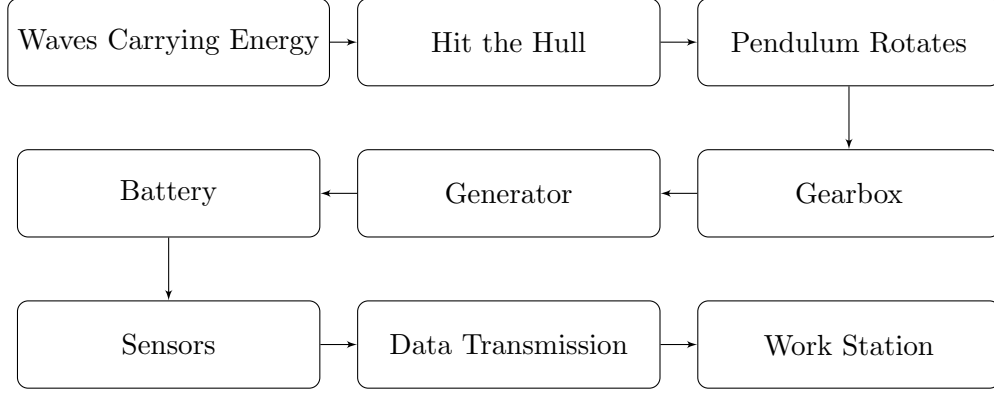

Figure 3: Demonstration of System Flow for Pendulum-Based WECs

13 Historical Context and Significance

The initial concept for horizontal pendulum wave energy converters emerged with the 1966 patent by Thiokol Chemical Corporation, intended for powering maritime navigational aids. Modern advancements by companies like Wello with their Penguin device and Neptune Wave Power enhance the technology's viability and efficiency, demonstrating significant potential in renewable energy sectors.

14 Dynamics and Mathematical Modeling

The dynamics of a PWEC involve complex interactions between the wave-induced motion of the hull and the consequent movement of an internal pendulum. The equations governing these dynamics are derived using principles from Lagrangian mechanics.

14.1 Mathematical Model

The total Lagrangian L for the PWEC system is expressed as:

$$L = T_{total} - V_{total} \quad (2)$$

where T_{total} and V_{total} denote the total kinetic and potential energies, respectively.

14.1.1 Equation of Motion for the Pendulum

The motion of the pendulum within the hull is generically described by the equation:

$$\ddot{\phi} = \frac{-gR_p \sin(\phi) \sin(\theta) + M_d + M_{gen}}{m_p R_p^2} \quad (3)$$

where ϕ and θ are the angular positions of the pendulum and the hull pitch, respectively, R_p is the length of the pendulum arm, and M_d , M_{gen} are the damping and generator moments. However, we started by studying the basic simple pendulum problem and advanced to study the oscillating the pendulum's pivot vertically and horizontally to simulate resonance and parametric resonance under of such system. To achieve the parametric resonance in the ocean, the pendulum will rotate in a horizontal plane as its vertical axis oscillates due to the wave excitation.

15 The Study of Pendulum Dynamics

In studying the numerical simulation of a simple pendulum under various conditions, we explore four primary scenarios: an undamped pendulum, a damped pendulum, a pendulum with an oscillatory pivot point in the horizontal direction and lastly a vertical excitation of the pivot (parametric excitation).

15.1 Undamped Pendulum

The equation of motion for a simple pendulum without damping or external forces is given by:

$$\ddot{\theta}(t) + \frac{g}{L} \sin(\theta(t)) = 0 \quad (4)$$

where θ is the angular displacement, g is the acceleration due to gravity, and L is the length of the pendulum.

We used the 4th-order Runge-Kutta method for numerical integration. The initial conditions were set to an initial angle of 6 degrees and an initial angular velocity of 0 rad/s.

The time domain and frequency domain results of the undamped case are presented below in figures 4,5. The natural frequencies of the system are calculated using the Fourier transform function and their values are: 0.266 Hz for $L=3$ m, 0.35 for $L=2$ m, and 0.5 for $L=1$ m. As the length of the pendulum increases, the natural frequency decreases.

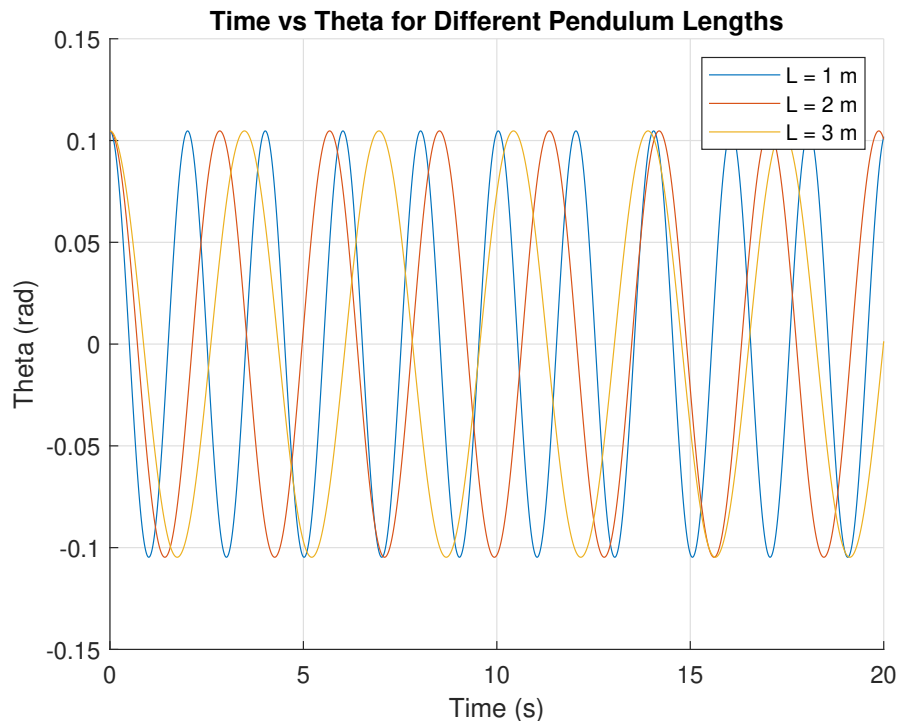

Figure 4: Time domain plot of the undamped pendulum.

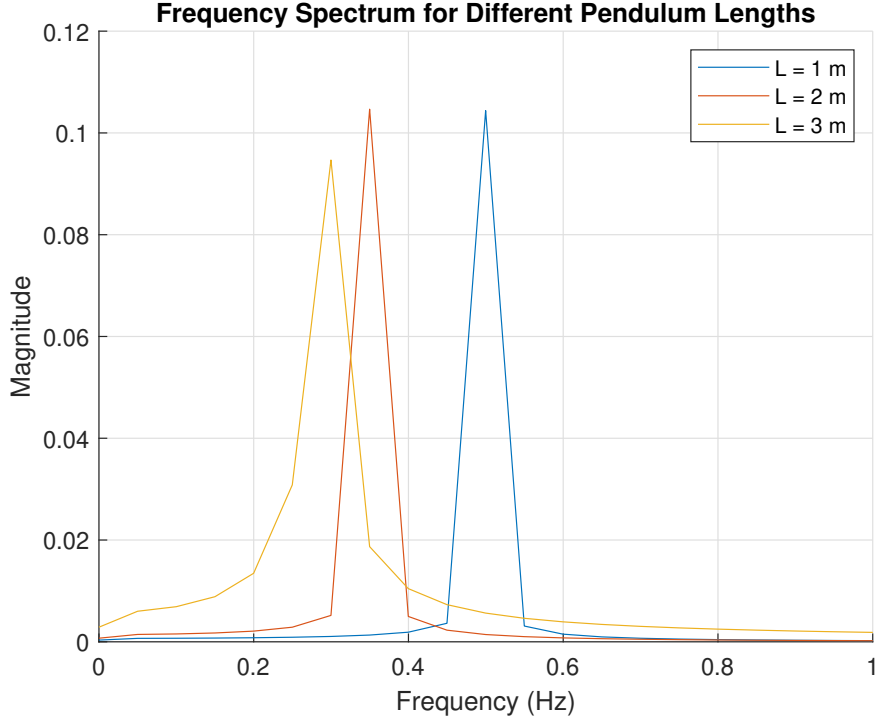

Figure 5: Frequency domain plot of the undamped pendulum.

15.2 Damped Pendulum

For the damped pendulum, a dissipative force proportional to the angular velocity is included:

$$\ddot{\theta}(t) + b\dot{\theta}(t) + \frac{g}{L} \sin(\theta(t)) = 0 \quad (5)$$

where b is the damping coefficient.

The time domain and frequency domain results of the undamped case are presented below in figures 6,7.

15.3 Horizontal excitation for the damped system

The matrix form of the driven oscillation system, considering the equations:

$$\begin{aligned} mL \cos(\theta)\ddot{\theta} - F_y &= mL(\dot{\theta})^2 \sin(\theta) - m\ddot{y} \\ mL \sin(\theta)\ddot{\theta} - F_z &= -mL(\dot{\theta})^2 \cos(\theta) - mg \\ L \cos(\theta)F_y + L \sin(\theta)F_z &= 0 \end{aligned}$$

can be written as:

$$\begin{bmatrix} mL \cos(\theta) & -1 & 0 \\ mL \sin(\theta) & 0 & -1 \\ L \cos(\theta) & 0 & L \sin(\theta) \end{bmatrix} \begin{bmatrix} \ddot{\theta} \\ F_y \\ F_z \end{bmatrix} = \begin{bmatrix} mL(\dot{\theta})^2 \sin(\theta) - m\ddot{y} \\ -mL(\dot{\theta})^2 \cos(\theta) - mg \\ 0 \end{bmatrix}$$

This system is nonlinear due to the trigonometric functions and their products with other variables, and as such, cannot be solved by linear algebraic methods directly. Numerical methods

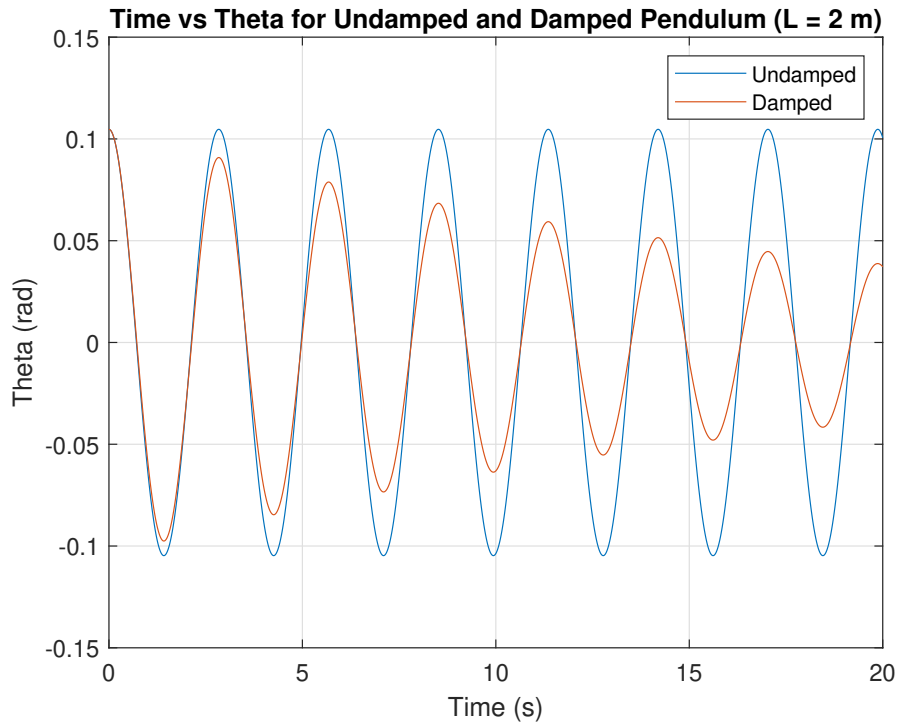

Figure 6: Time domain plot of the damped pendulum.

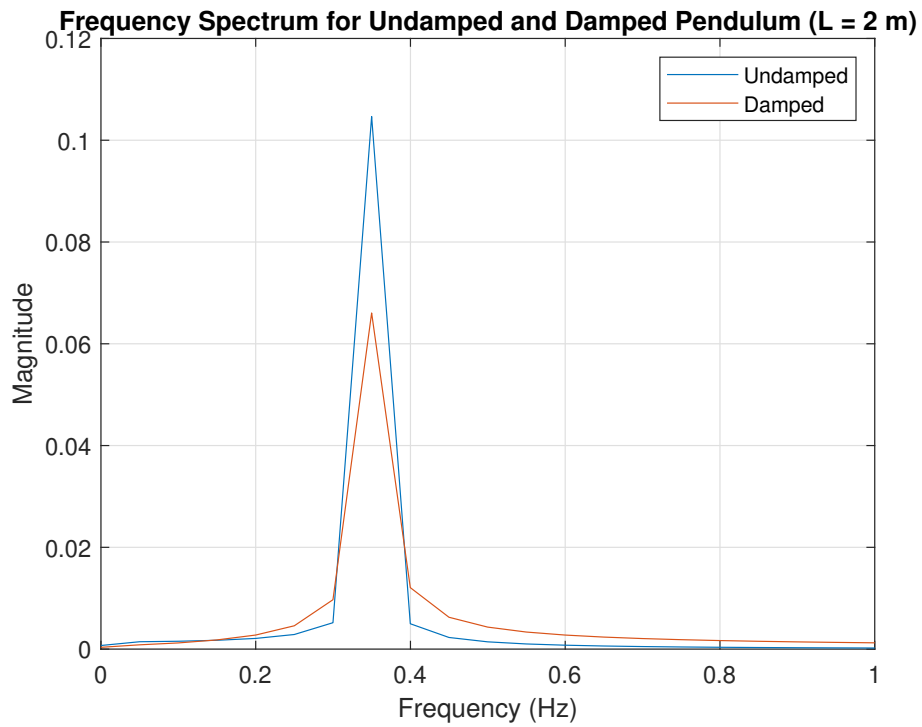

Figure 7: Frequency domain plot of the damped pendulum.

would be required.

The pivot of the pendulum undergoes a horizontal oscillatory motion described by:

$$y(t) = A \cos(2\pi ft) \quad (6)$$

where A is the amplitude and f is the frequency of oscillation. $A=1$, $f=0.3$ Hz. Note that this chosen frequency is very close to the natural frequency of the $L=2,3$ m cases.

The modified equation of motion for the undamped system becomes:

$$\ddot{\theta}(t) + \frac{g}{L} \sin(\theta(t)) = \frac{A}{L} \cos(\theta(t)) \cos(2\pi ft) \quad (7)$$

The time domain and frequency domain results of the undamped case are presented below in figures 8,9.

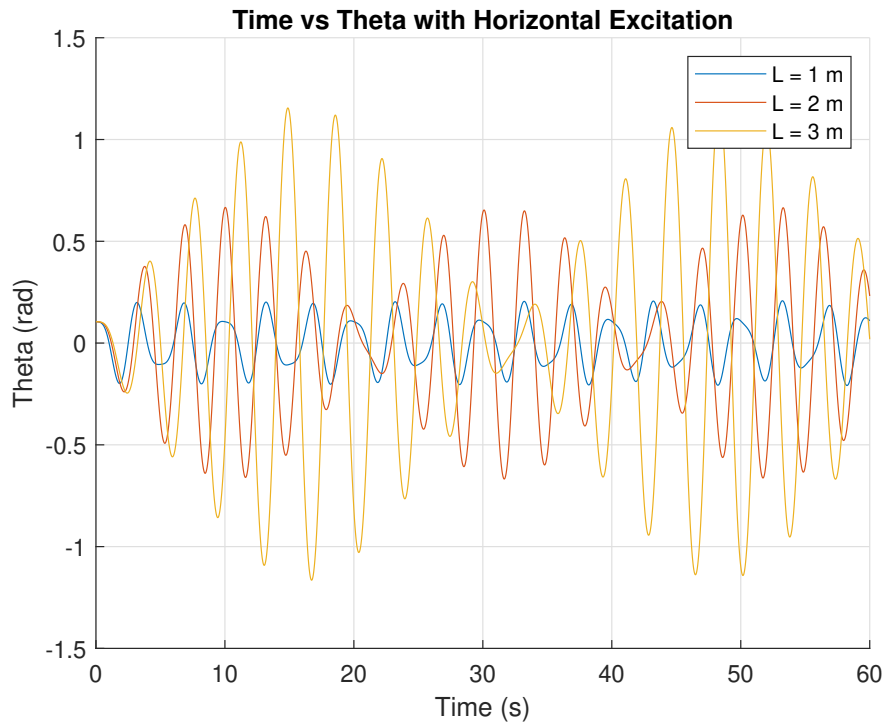

Figure 8: Time domain plot of the damped pendulum.

The pendulum oscillation is no longer a sinusoidal function with one frequency, but a superposition of two frequencies (i.e. driven excitation and natural frequencies). The peak amplitude occurs at 0.3 Hz due to resonance, as this excitation frequency is close to the natural frequencies of cases $L=2$, $L=3$ m. As a result, their amplitudes increase over time. The natural frequencies of the system did not change.

15.4 Parametric excitation for the damped system (vertical oscillation)

The equation of motion for a simple pendulum with a vertically oscillating pivot is given by:

$$\ddot{\theta} = (g + \ddot{z}) * \left(\frac{\cos(\theta)}{L} \right) \quad (8)$$

where:

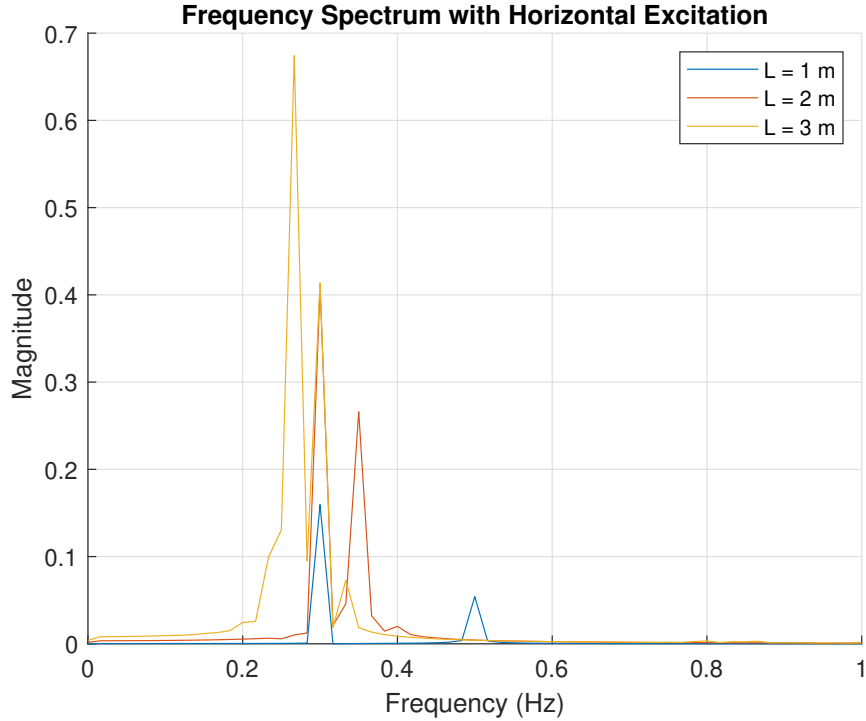

Figure 9: Frequency domain plot of the damped pendulum.

- θ is the angular displacement,
- g is the acceleration due to gravity,
- L is the length of the pendulum, and
- \ddot{z} is the vertical acceleration of the pivot.

The vertical acceleration z is often modeled as a sinusoidal function, such as $\ddot{z} = \cos(2\pi ft)$, where f is the frequency of oscillation.

The dynamics of the pendulum were simulated using MATLAB, considering different lengths of the pendulum and the effect of varying frequencies of vertical oscillation.

The simulations were performed for pendulum lengths of 1, 2, and 3 meters, with an initial angular displacement of 6 degrees and zero initial angular velocity. The frequency of vertical oscillation was set to 2×0.35 Hz.

The following figures illustrate the time-domain and frequency-domain responses of the pendulum under vertical oscillation for the various lengths.

Parametric excitation occurs at $L=2$ m case, since the excitation frequency is twice the natural frequency of this case.

16 Pendulum in a Floating Body

Now let us delve into the analysis of the dynamics of a floating body with a pendulum. The system is modeled as a vertical axis parametric pendulum and is subjected to various forces and motions due to its interaction with the hull of a vessel.

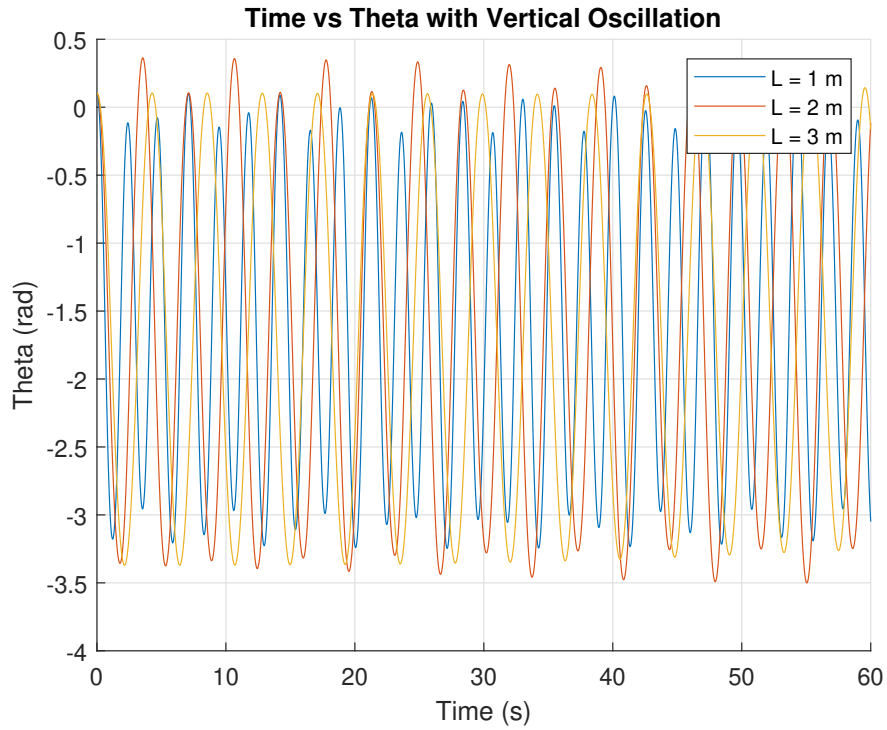

Figure 10: Time-domain response of the pendulum for different lengths.

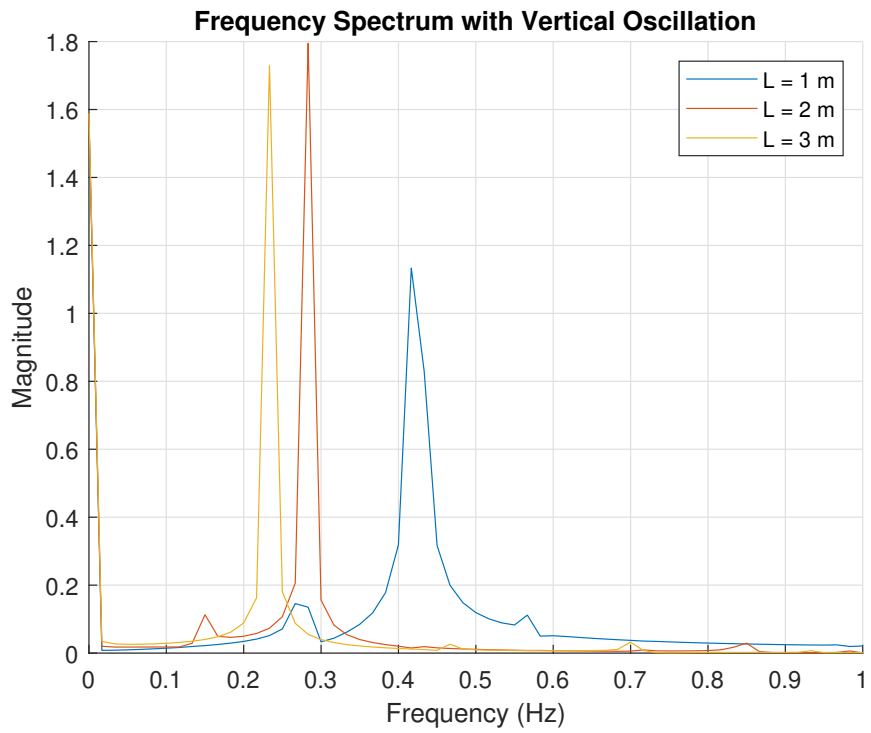

Figure 11: Frequency-domain response of the pendulum for different lengths.

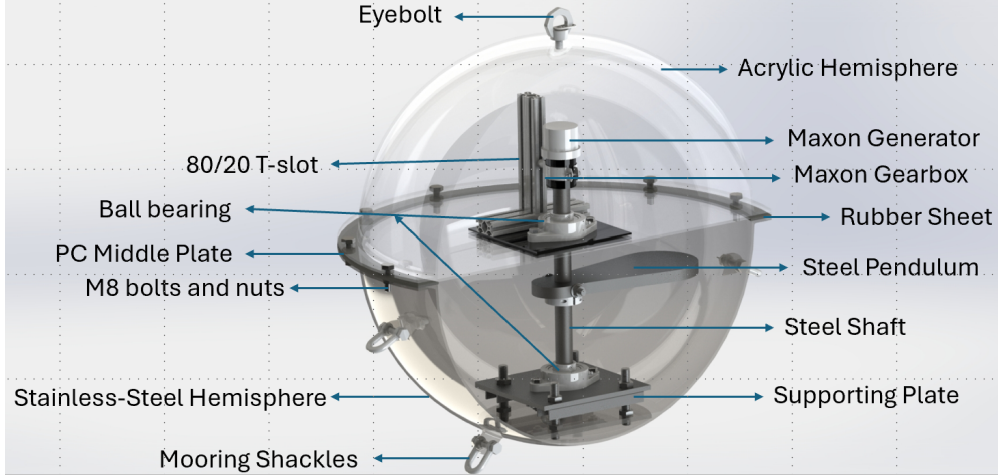

Figure 12: Pendulum Design Configuration

16.1 Governing Equations of Motion

The dynamics of the pendulum are governed by the following differential equations:

$$Ml^2\ddot{\theta} + b\dot{\theta} + Mgl \sin \theta = Mlf''(t) \sin \theta \quad (9)$$

$$(Ml^2 + J)\ddot{\theta} + b\dot{\theta} + s|\dot{\theta}|\dot{\theta} + F_c = -((Ml^2 + J)AR_z + Ml(g_y - a_y) \sin \theta + (g_x - a_x) \cos \theta) \quad (10)$$

where θ is the angular displacement of the pendulum, M is the mass of the pendulum, l is the length of the pendulum, J is the moment of inertia about the pendulum's center of mass, b is the linear damping coefficient, s is the nonlinear damping coefficient, g is the acceleration due to gravity, and AR_z , g_x , g_y , a_x , and a_y are the accelerations and angular accelerations associated with the hull's motion.

A detailed analysis of the dynamics of a pendulum attached to a floating body was conducted and simulate din MATLAB. The study is based on a mathematical model that considers various forces and motions affecting the pendulum due to its interaction with a moving hull.

The system is modeled as a vertical axis parametric pendulum subjected to forces due to gravity, damping, and hull motion. The key assumptions made in the model are as follows:

- The pendulum is assumed to have a mass of M , length l , and moment of inertia J about its center of mass.
- The damping effects are represented by linear and nonlinear damping coefficients b and s , respectively.
- The hull's motion contributes to the pendulum's dynamics through linear and angular accelerations.

The simulation results are presented in the figure below. The figure shows the angular position and velocity of the pendulum for different motion scenarios including oscillation, pure rotation, chaotic motion, large amplitude rotation, and oscillation-rotation 13.

16.2 Angular Position and Velocity

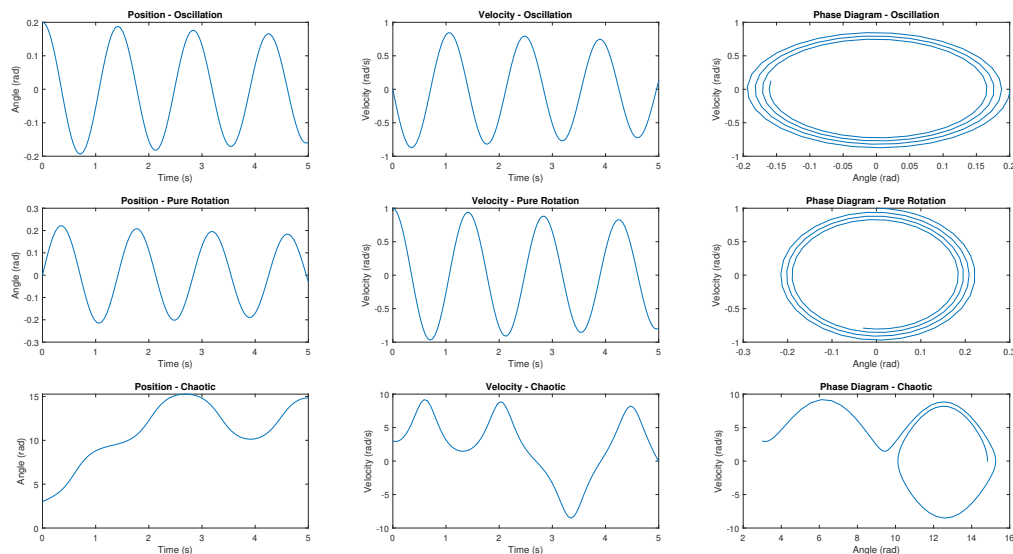

Figure 13: Angular Position and Velocity of the Pendulum

The analysis and simulation demonstrate the complex dynamics exhibited by a pendulum attached to a floating body under various motion scenarios.

17 Ocean Wave Modeling

The simulation of the PWEC's interaction with ocean waves is critical for evaluating its performance and is modeled using both regular and irregular wave patterns that replicate the Oregon coast's wave environment.

17.1 Wave Forces

The forces exerted by the waves on the PWEC are critical for determining its motion and are calculated using potential flow theory. The wave force F is given by:

$$F = \rho g A \cos(kx - \omega t + \epsilon) \quad (11)$$

where ρ is the water density, g is the acceleration due to gravity, A is the wave amplitude, k is the wave number, ω is the angular frequency, x is the position, t is time, and ϵ is the phase constant.

17.2 Irregular Waves Spectrum

The JONSWAP (Joint North Sea Wave Project) spectrum is a widely used model for characterizing irregular sea waves, particularly in the context of the North Sea. It provides a statistical representation of ocean waves by defining the wave energy distribution over different frequencies. Below, we graphed the wave elevation and spectral density for both cases; the full scale and the scaled model.

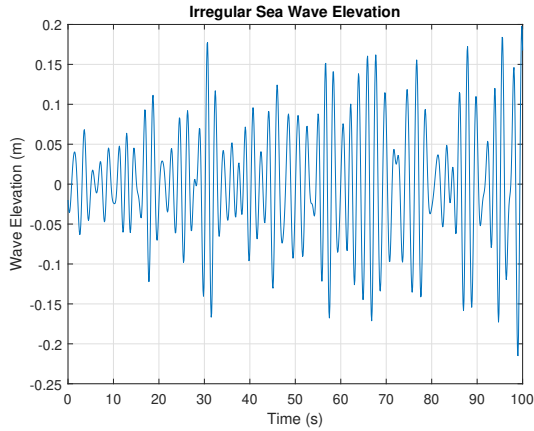

((a)) Wave Elevation

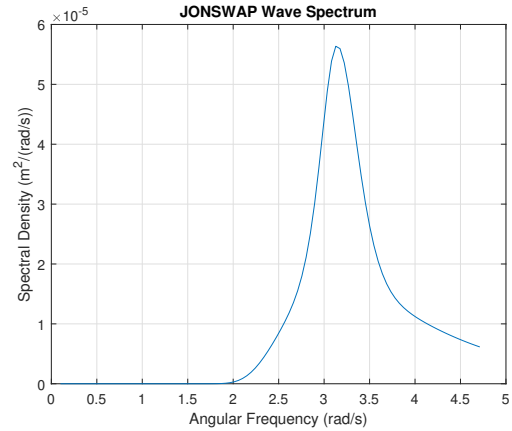

((b)) Wave Spectrum

Figure 14: Irregular Wave Elevation and Spectral Density (Scaled Model Analysis)

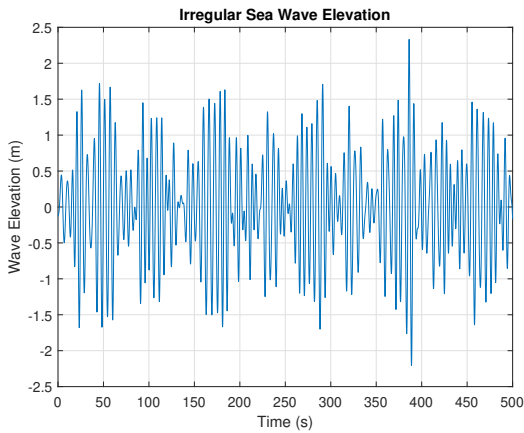

((a)) Wave Elevation

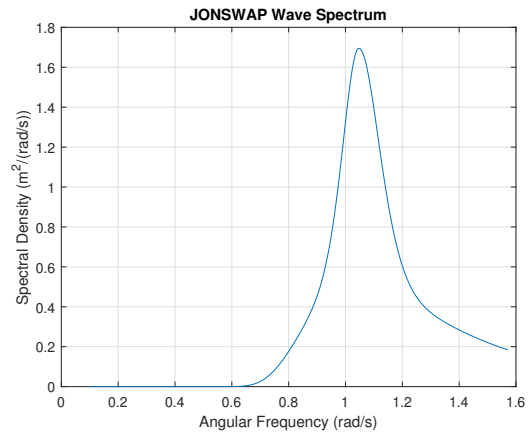

((b)) Wave Spectrum

Figure 15: Irregular Wave Elevation and Spectral Density (Full Model Analysis)

The pendulum exhibits a chaotic motion under the effect of irregular waves.

18 Power Performance Analysis

The aim of this section is to provide an examination of our project's energy efficiency and output. This involves analyzing power generation under various conditions, such as different sea states. We will evaluate the system's performance metrics, including efficiency at converting energy, reliability under varying operational conditions, and the potential for scalability. Additionally, comparisons against industry standards and potential improvements will be explored. The key areas of analysis include:

- Efficiency at converting energy.
- Generator's efficiency.

- Margin of error.
- Factors that contribute to inaccurate data collection.
- Reliability under varying operational conditions.
- Scalability.
- Total cost to produce this device.
- Transferability and compatibility of data collectors and transmissions.

18.1 Power Generation Under Different Sea States

18.1.1 Approach

Our goal was to create a program that could easily be adapted to different data sets and be applicable to buoys throughout the blue economy. It would serve as a tool to compare historical data and identify sea states to help set testing conditions similar to the location of deployment.

The program utilized historical data from the year 2023 of the waverider buoy Station 44091 of the U.S Army Corps of Engineers located in Barnegat, NJ **NOAA44091** and Station 46050 of the National Data Buoy Center in Newport, OR **NOAA46050**. These buoys were chosen because of their long records of historical data and active collection of the information needed to predict ideal power output at a location near our test sites - our campus in Hoboken, NJ, which is approximately 90 miles away from Barnegat, and the South PacWave Test Site, also in Newport, OR, where the final MECC presentations would be held. Stations 44091 and 46050 collected significant wave height (WVHT - the average height of the highest third of waves during a 20-minute sampling period), dominant wave period (DPD - the period with the maximum wave energy), average wave period (APD - the average period of all waves during a 20-minute sampling period), mean wave direction (MWD - the direction from which the waves of the DPD are approaching the buoy), and water temperature (WTMP - sea surface temperature). For condensation purposes, all excerpts of code will be in reference to Station 44091; the code for Station 46050 is identical.

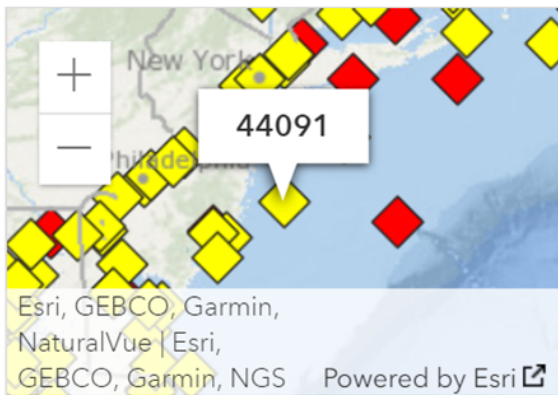

((a)) Station 44091 Location

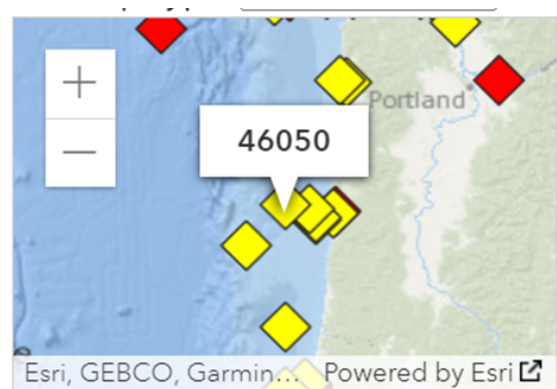

((b)) Station 46050 Location

Figure 16: Locations of Different Stations

Since the original data set was a second-by-second record of an entire year, it was necessary to first make this information digestible. MATLAB was chosen for analytics because of its graphical

and computational capability. In order to sort through the data, which was compiled into a text file (txt), the headers labeling each column of data had to be deleted so that each element in the column would be a uniform data type. An original copy of the unedited data set was kept separate from the MATLAB file for reference.

#YY	MM	DD	hh	mm	WDIR	WSPD	GST	WVHT	DPD	APD	MWD	PRES	ATMP	WTMP	DEWP	VIS	TIDE
#yr	mo	dy	hr	mn	degT	m/s	m/s	m	sec	sec	degT	hPa	degC	degC	degC	mi	ft
2023	01	01	00	26	999	99.0	99.0	0.98	11.11	5.80	139	9999.0	999.0	6.5	999.0	99.0	99.00
2023	01	01	00	56	999	99.0	99.0	1.21	11.11	6.19	145	9999.0	999.0	6.5	999.0	99.0	99.00
2023	01	01	01	26	999	99.0	99.0	1.29	6.67	6.20	146	9999.0	999.0	6.5	999.0	99.0	99.00
2023	01	01	01	56	999	99.0	99.0	1.57	7.14	6.38	156	9999.0	999.0	6.5	999.0	99.0	99.00
2023	01	01	02	26	999	99.0	99.0	1.77	7.14	6.36	149	9999.0	999.0	6.5	999.0	99.0	99.00
2023	01	01	02	56	999	99.0	99.0	1.68	7.69	6.38	160	9999.0	999.0	6.5	999.0	99.0	99.00
2023	01	01	03	26	999	99.0	99.0	1.72	8.33	6.33	160	9999.0	999.0	6.5	999.0	99.0	99.00
2023	01	01	03	56	999	99.0	99.0	1.83	7.69	6.54	159	9999.0	999.0	6.6	999.0	99.0	99.00
2023	01	01	04	26	999	99.0	99.0	1.78	7.69	6.42	160	9999.0	999.0	6.6	999.0	99.0	99.00
2023	01	01	04	56	999	99.0	99.0	1.87	8.33	6.62	167	9999.0	999.0	6.6	999.0	99.0	99.00
2023	01	01	05	26	999	99.0	99.0	1.91	8.33	6.72	164	9999.0	999.0	6.6	999.0	99.0	99.00
2023	01	01	05	56	999	99.0	99.0	1.76	8.33	6.72	164	9999.0	999.0	6.6	999.0	99.0	99.00
2023	01	01	06	26	999	99.0	99.0	1.90	8.33	6.84	166	9999.0	999.0	6.6	999.0	99.0	99.00
2023	01	01	06	56	999	99.0	99.0	1.75	8.33	6.88	164	9999.0	999.0	6.5	999.0	99.0	99.00
2023	01	01	07	26	999	99.0	99.0	1.97	8.33	7.16	164	9999.0	999.0	6.5	999.0	99.0	99.00
2023	01	01	07	56	999	99.0	99.0	1.76	9.09	6.98	161	9999.0	999.0	6.5	999.0	99.0	99.00
2023	01	01	08	26	999	99.0	99.0	1.71	8.33	6.96	164	9999.0	999.0	6.5	999.0	99.0	99.00
2023	01	01	08	56	999	99.0	99.0	1.76	8.33	7.25	163	9999.0	999.0	6.5	999.0	99.0	99.00
2023	01	01	09	26	999	99.0	99.0	1.68	8.33	6.99	160	9999.0	999.0	6.4	999.0	99.0	99.00

Figure 17: Original Data

```
fileid = fopen('44091h2023.txt', 'rt');
if fileid == -1
    disp('Error, check file name')
else
    C = textscan(fileid, '%f %f %f %f %f %f %f %f %f %f %f %f %f %f %f %f %f %f');
    den = 1000; %density in kg/m^3 - change depending on which units the data is collected in
    g = 9.8; %force of gravity in m/s^2
    %h = C{9}; %significant wave height in m
    %dt = C{10}; %dominant wave period in s
    %t = C{11}; %average wave period in 20 minute intervals in s
    h2023 = readmatrix('44091h2023.txt');
```

Figure 18: Reading txt File

18.1.2 Power and Frequency Calculations

The wave energy formula (Equation 12) was utilized to calculate the theoretical power generated, and the wave frequency (Equation 13) was also calculated as it is a major component for our device's pendulum rotation and power output **wave-energy-calculator**. The formulas were verified by hand and using online calculators to ensure their equivalence and accuracy.

$$\text{Power} = \frac{1}{16} \cdot \rho \cdot g \cdot H_s^2 \cdot T_p \quad (12)$$

$$\omega = \frac{2\pi}{T} \quad (13)$$

To calculate the power and frequency, the program first checks whether the value in the month column falls within a specified range. For example, for January, the range is 0 to 2. If this condition is true, a new matrix is derived from the original, containing only the data collected during the selected month. The wave height and period are extracted into arrays from their respective columns. However, the power and frequency, as calculated values, did not have pre-existing columns from

the original set to draw from. Initially, an empty array was created to store each line’s calculations as the last element, with each loop reiteration. However, this method was inefficient and often caused indexing errors due to significant overhead. To fix this issue, arrays of zeros were created to match the length of the new matrix. As the code iterated, it replaced the corresponding 0 with the calculated value.

```

h2023 = readmatrix('44091h2023.txt');
low = 0;
high = 2;
for m = 1:12 %Changing the upper limit will change which month's data the graph will produce
    index = h2023(:,2) > low & h2023(:,2) < high;
    new_matrix = h2023(index,:);
    power = zeros(length(new_matrix),1);
    f = zeros(length(new_matrix),1);
    h = zeros(length(new_matrix),1);
    t = zeros(length(new_matrix),1);
    for i = 1:length(new_matrix)
        h_plot = new_matrix(i,9);
        t_plot = new_matrix(i,11);
        if t_plot == 99
            continue;
        end
        pow = (den.*g^2*t_plot*h_plot^2)/(64.*pi);
        power(i) = pow;
        frequency = (2.*pi)/t_plot;
        f(i) = frequency;
        h(i) = h_plot;
        t(i) = t_plot;
    end
end

low = low +1;
high = high +1;
end

```

Figure 19: Month Loop with Power and Frequency Calculation

After all lines of the new matrix were sorted, the low and high numbers were increased by one to move to the next month. The final hurdle was displaying the information. Complying with industry standards, we programmed various scatter diagrams to display the frequency of certain wave climates and power outcomes **matlab-subplot-tutorial**. There was a single data point during September and October that incorrectly captured the APD to be 99 seconds and would thus generate a skewed graph. An **if** condition was added to bypass this line of data. The code also checks the value under the new matrix’s month column to title the graphs accordingly.

18.1.3 Parameters Acquired for WEC Modeling

Parameter	Notation
Significant Wave Height (WVHT)	H
Average Wave Period (APD)	T
Power (W/m)	P
Angular Frequency (rad/s)	ω

Table 5: Parameters acquired for WEC modeling.

18.2 Results: Station 46050 in Oregon

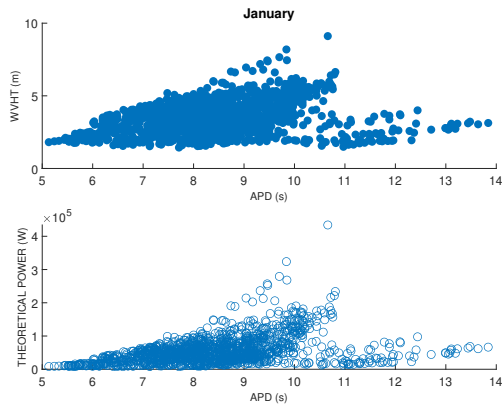

((a)) January Data

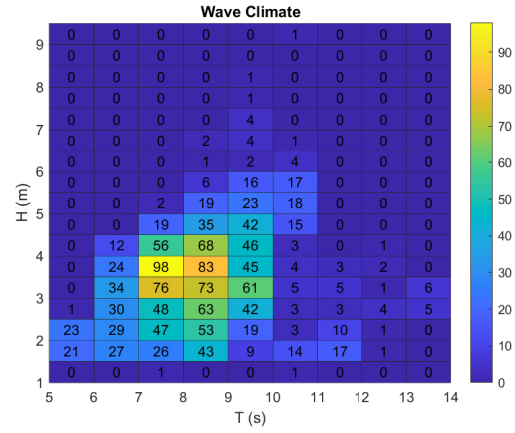

((b)) January Power Matrix

Figure 20: January Figures

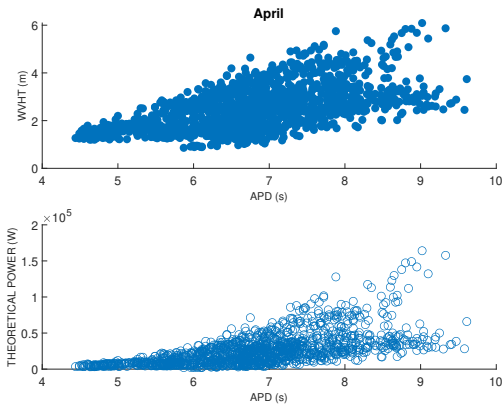

((a)) April Data

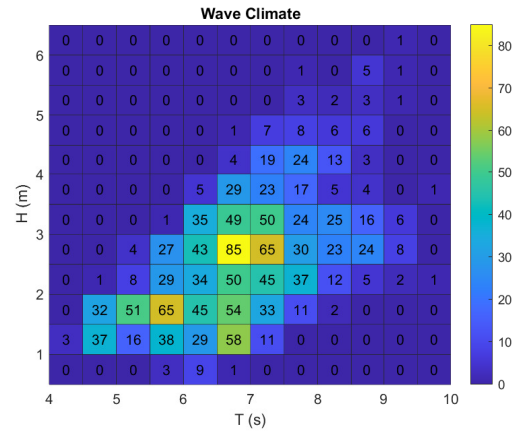

((b)) April Power Matrix

Figure 21: April Figures

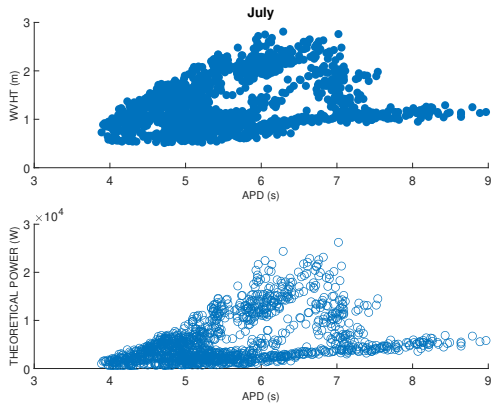

((a)) July Data

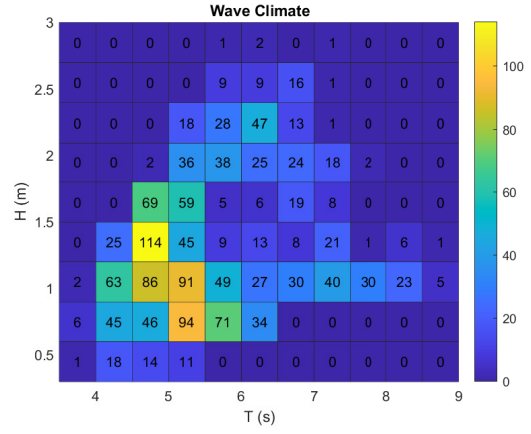

((b)) July Power Matrix

Figure 22: April Figures

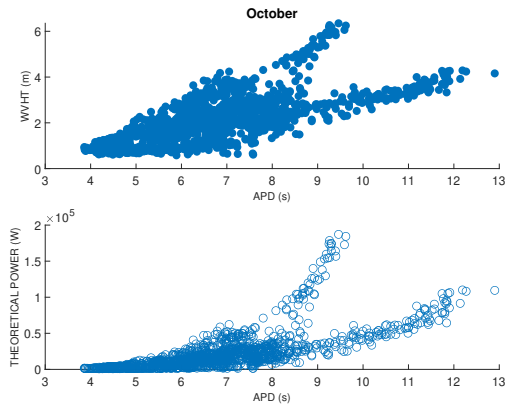

((a)) October Data

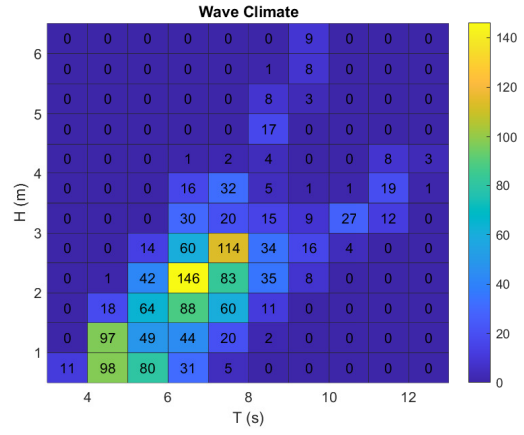

((b)) October Power Matrix

Figure 23: October Figures

18.3 Results: Station 444091 in New Jersey

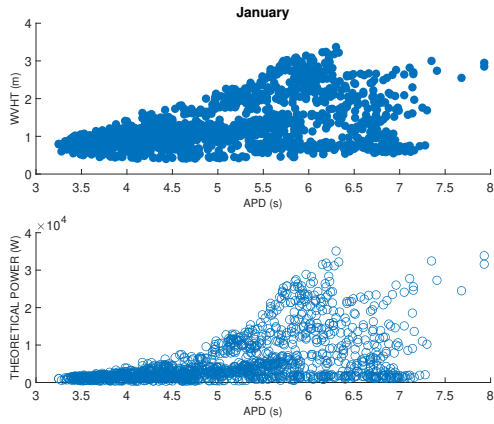

((a)) January Data

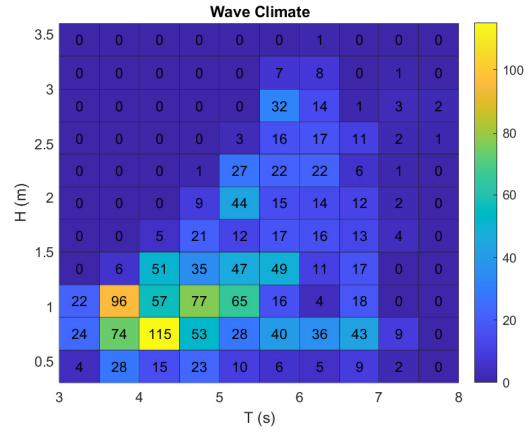

((b)) January Power Matrix

Figure 24: January Figures

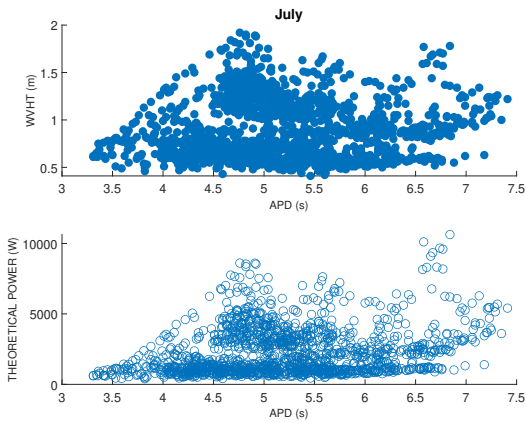

((a)) July Data

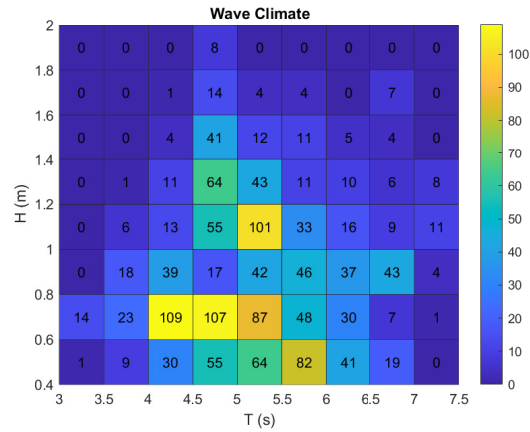

((b)) July Power Matrix

Figure 25: April Figures

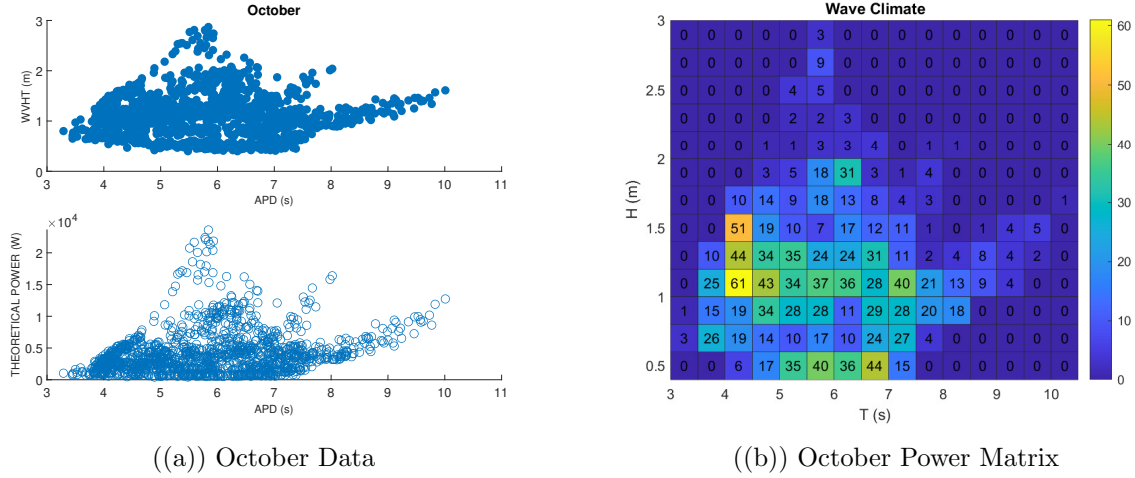

Figure 26: October Figures

18.4 Sea State Code by Month

Month	Average WVHT (m)	Code Number
January	1.264	4
February	1.3801	4
March	1.4153	4
April	1.1766	3
May	1.1719	3
June	1.0877	3
July	0.8912	3
August	0.9976	3
September	1.5646	4
October	1.1183	3
November	1.1836	3
December	1.2936	4

Table 6: Sea State Code by Month for Station 44091 in 2023

18.5 Performance Metrics

18.5.1 Efficiency at Converting Energy

The efficiency at converting energy is a key performance metric that determines how effectively the system can capture and convert the energy present in the marine environment. This metric should be compared against industry standards to identify areas for improvement. The generator's efficiency should also be assessed, including any margin of error in the measurements or calculations.

18.5.2 Reliability under Varying Operational Conditions

The system's reliability under varying operational conditions, such as low wind speeds and less aggressive waves, is crucial for ensuring consistent power generation. Factors that contribute to

Month	Average WVHT (m)	Code Number
January	1.1362	3
February	1.2319	3
March	0.8513	3
April	0.8362	3
May	0.5848	3
June	0.5710	3
July	0.4353	2
August	0.4698	2
September	0.7253	3
October	0.7175	3
November	0.8984	3
December	1.1091	3

Table 7: Sea State Code by Month for Station 46050 in 2023

inaccurate data collection should be identified and mitigated where possible.

18.5.3 Scalability

The potential for scalability should be evaluated in coordination with other team members, such as Amira and Shah, to assess the feasibility of scaling up the prototype to meet market demands.

18.6 Comparison Against Industry Standard

The system should be compared against industry standards to justify its competitiveness at the proposed market locations. The cost-optimal ratio of conversion capacity to battery storage should be assessed. Additionally, the transferability and compatibility of data collectors and transmissions should be considered.

18.6.1 Cost-Competitiveness and Battery Storage

The system’s cost-competitiveness and optimal ratio of conversion capacity to battery storage should be evaluated. This involves researching why this system is a better proposition compared to just using a battery and assessing how much energy is consumed by the pendulum and electrical components.

18.6.2 Comparison with NexSens Technology

Our major competitors in this market include NexSens Technology Inc., a company that produces solar-powered data buoys. The NexSens CB-75 data buoy is fitted with three 4-watt solar panels and an internal sealed lead acid (SLA) battery for its X3-SUB data logger, which houses electronics but must be bought separately. The CB-75 is composed of a cross-linked polyethylene foam and a steel frame, weighing 40 lb and measuring 21” in diameter. The CB-75 Data Buoy sends data in real-time to the cloud-based WQData LIVE datacenter. Although pricing information is not directly available on the NexSens website, a Swedish commerce site for environmental monitoring devices offers the CB-75 for approximately \$3000 USD **nexsens-cb75**.

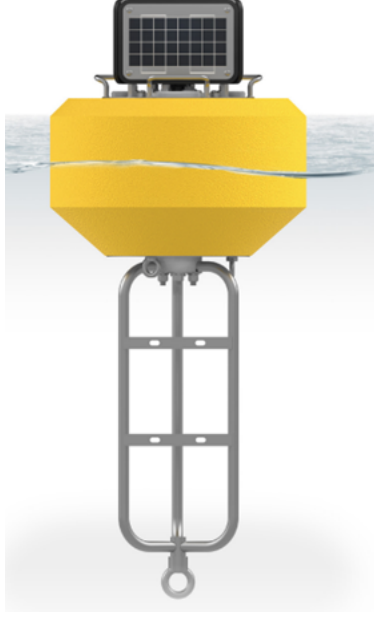

Figure 27: CB-75 Data Buoy

19 Scaling and Power Calculations

To analyze the horizontal pendulum system excited by a sine wave in a wave tank, of mass 5 kg and 0.27 m in length, we simply calculated the theoretical resulting torque, rotational speed (RPM), and wave power for different wave frequencies when The sine wave displaces the pivot of the pendulum,.

$$y(t) = A \sin(\omega t + \phi), \quad (14)$$

where A is the amplitude, ω is the angular frequency, and ϕ is the phase offset.

The vertical displacement of the wave exerts a force on the pendulum:

$$F(t) = -mA\omega^2 \sin(\omega t + \phi). \quad (15)$$

The resulting torque τ on the pendulum is:

$$\tau(t) = F(t) \cdot L = -mAL\omega^2 \sin(\omega t + \phi). \quad (16)$$

The pendulum's angular displacement $\theta(t)$ can be modeled as:

$$\theta(t) = B \sin(\omega t + \phi + \delta), \quad (17)$$

where B and δ are constants. The angular velocity ω_θ is:

$$\omega_\theta = \frac{d\theta}{dt} = B\omega \cos(\omega t + \phi + \delta). \quad (18)$$

The RPM of the pendulum is:

$$\text{RPM} = \frac{\omega_\theta}{2\pi} \times 60. \quad (19)$$

The power P of the wave is given by:

$$P = \frac{\rho g^2 H^2 T}{64\pi}, \quad (20)$$

where ρ is the water density, g is the gravitational acceleration, H is the wave height, and T is the wave period.

The plots generated by the MATLAB code are shown below:

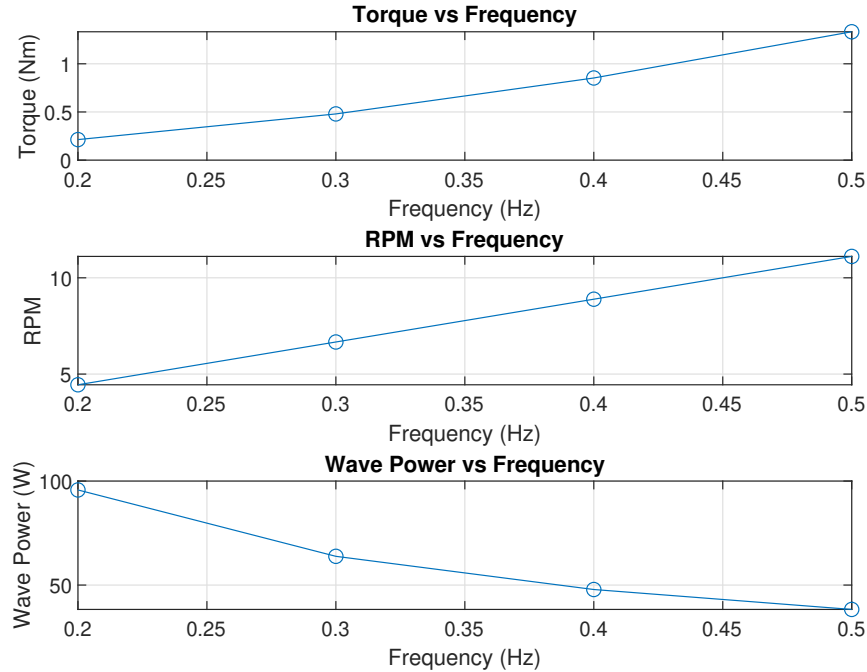

Figure 28: Torque, RPM, and Wave Power as Functions of Frequency.

From the plots, we can observe the following:

- The torque increases with increasing frequency, which is expected as torque is proportional to ω^2 .
- The RPM also increases with frequency, which aligns with the expectation as the angular velocity is directly proportional to ω .
- The wave power decreases with increasing frequency, which can be attributed to the T term in the formula, where $T = 1/f$.

19.1 Froude Similarity Analysis of a Wave Energy Converter

The scaling of a wave energy converter took place using Froude similarity. The scaled model has a diameter of 0.7m while the full-scale prototype has a diameter of 6m. The model hull weighs 39kg and the pendulum weighs 5kg with a length of 0.27m. The following table compares the full-scale masses and wave parameters, as well as the power generated in each case. The model wave amplitude ranges from 5 cm to 20 cm, and the wave periods range from 1.5seconds to 3seconds.

Parameter	Full Scale	λ Factor	Scaled Model
Diameter (m)	6	λ	0.7
Hull Mass (kg)	24,559.77	λ^3	39
Pendulum Mass (kg)	3,148.69	λ^3	5
Pendulum Length (m)	2.31	λ	0.27
Wave Amplitude (m)	[0.43, 1.71]	λ	[0.05, 0.2]
Wave Period (s)	[4.39, 8.78]	$\sqrt{\lambda}$	[1.5, 3.0]
Wave Power (W)	[1,544.30, 12,354.42]	λ^3	[0.73, 5.88]

Table 8: Comparison of Full Scale and Scaled Model Values.

20 Reliable Data Collection and Transmission in Oceanic Environments

The aim of this section is to develop a robust system for reliably collecting and transmitting vital sensory data from oceanic environments. Our team has developed a dual transmission system within the buoy, comprising a primary system and a secondary system. The primary power system, which includes lead batteries, powers the main components, such as an Arduino and sensors, under normal conditions. The secondary power system, equipped with lithium batteries, serves as a backup power source. The power source is generated by the excited pendulum that is coupled with a generator and two charge controllers to manage the charging process and ensure continuous operation. A specially designed circuit monitors a heartbeat signal from the primary system and activates the backup system if no signal is detected. This features a fail-safe mechanism to ensure reliable data transmission and incorporates design considerations to minimize energy consumption, thereby enhancing the device’s operational sustainability.

20.1 The Onboard Computer Circuit

For data transmission, we chose Arduino as our primary processor due to its ease of implementation and wide sensor compatibility. The chosen means of data transmission is radio, which is cost-effective compared to alternatives such as satellite transmission. It also has a larger range than other methods such as Wi-Fi or Bluetooth. The device initially focuses on measuring water turbidity and temperature, with plans to expand to include metrics such as salt concentration and ocean currents. The power system of the pendulum-based wave energy converter is a hybrid of lead and lithium batteries ???. To charge the batteries for continuous data transmission over long voyages, we

Battery Type	Voltage	Powered Systems
Lithium Battery	12V	Arduino and Sensors
Lead Battery	6V	Circuit and Other Systems

Table 9: Battery Power System

use appropriate gear ratios to maximize energy output with our generator. The electricity powers two charge controllers, which manage the charging rate and power to each battery, ensuring optimal charge throughout the deployment.

20.2 Fail-System Mechanism

The Arduino includes an internal fail-safe system called a "Watchdog Timer." This feature addresses software issues but not hardware issues. Since our device uses various sensors, physical damage such as water damage poses a more significant threat than software errors. Thus, a system ensuring proper hardware functionality is necessary. In developing our fail-safe system, we prioritized certain key requirements. The system must reroute power in the event the primary module fails or becomes unresponsive due to program or module issues, while ensuring a cost effective, yet reliable with minimal power consumption design. We then we devised a "Heartbeat Circuit." This circuit interprets heartbeat signals from the primary Arduino, signifying proper processor function. To minimize power usage, we avoided a setup with three separate Arduinos. In a conventional three-Arduino configuration, the primary Arduino transmits a heartbeat to a secondary Arduino, which reroutes power to a tertiary Arduino in the absence of the heartbeat signal. This approach requires constant power supply to two Arduinos and introduces a vulnerability if the receiver malfunctions. Our Heartbeat Circuit, optimized for low power consumption, uses low-power modules and ICs to replicate the functionality of an Arduino programmed to interpret heartbeat signals. We went through three iterations to ensure a smooth effective power transmission.

20.2.1 First Iteration

In our initial design, depicted in Figure 29, Arduino 1 received the main power and sent a signal to Relay 3, turning it off. If the Arduino couldn't send the signal, Relay 3 switched on, starting the timer delay. After 5 seconds, it signaled Relay 2 to send power to Arduino 2 and cut power to Arduino 1.

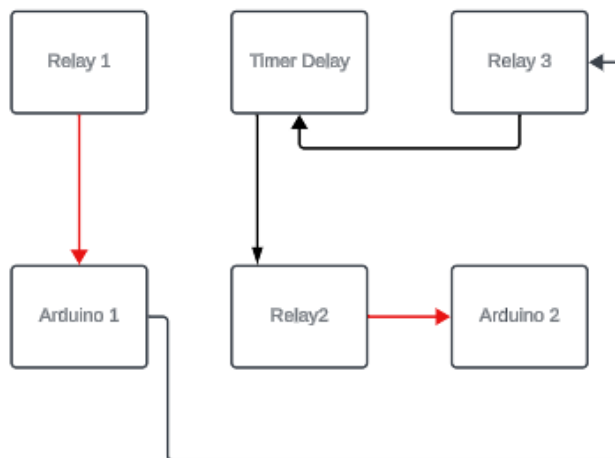

Figure 29: First Iteration

20.2.2 Final Iteration

In our final design, as depicted in Figure 30, Comparator 1 compares the timer circuit's signal to a 2V voltage source to prevent premature tripping. Comparator 2 compares Comparator 1's voltage to Arduino 1's signal. Initially, Arduino 1 is powered and sends a signal to Comparator 2. If the Arduino signal is higher, the Comparator does not activate the relays, keeping Arduino 1 powered. If Arduino 1 cannot send power, the Comparator signals Relay 1 to switch off and Relay 2 to switch on, powering Arduino 2 and turning off Arduino 1.

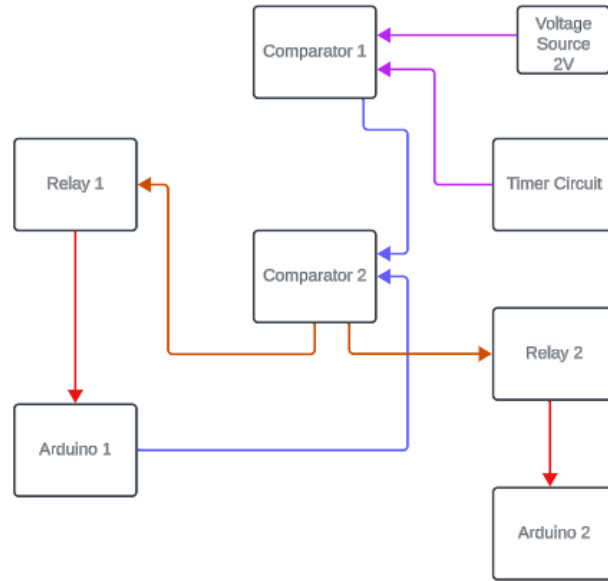

Figure 30: Final Iteration

21 Data Retrieval

21.1 Temperature

For temperature measurement, we chose the DS18B20 temperature sensor. The DS18B20 is a one-wire digital temperature sensor requiring one data line to communicate with the Arduino. The sensor requires 3-5.5V, operates from -55°C to 125°C , and has an accuracy of $\pm 0.5^{\circ}\text{C}$.³¹



Figure 31: DS18B20 Temperature Sensor

21.2 Turbidity

Turbidity is measured in Nephelometric Turbidity Units (NTU). Clear water is around 1 NTU, and the sensor detects turbidity from 0 to 4550 NTU. The sensor uses a light-emitting diode and receiver to measure turbidity; more particulates weaken the signal. The sensor returns a voltage signal read by the Arduino, from 0 to 800 units. A reading of 800 indicates clear water; lower readings indicate particulates obstructing the diode's path^{32, 33}.

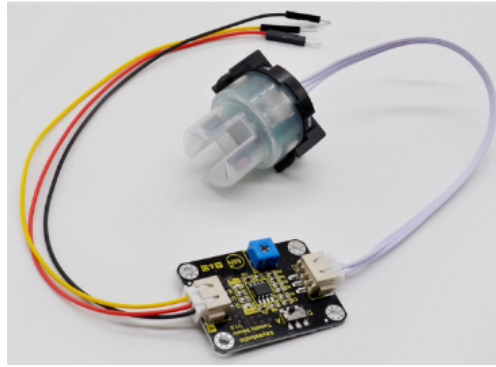

Figure 32: Turbidity Sensor

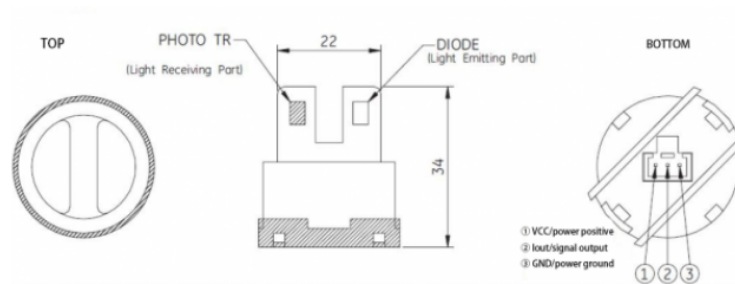

Figure 33: Turbidity Sensor Dimensions

22 Data Transmission

To transmit data over large distances, we explored various methods. Wi-Fi and Bluetooth offer high data transfer rates, but have limited range and are more vulnerable to unauthorized access. Satellite transmission provides coverage in remote areas, but is costly. Radio frequency transmission is cost-effective and has impressive range. We chose the nRF24L01 radio module, which can transmit up to 1000 meters. The module uses 125 different channels, allowing 125 different modules to be used in close proximity.

23 Protection System Description

The purpose of this project is to protect the electronic and metal components within the enclosure. The goal is to ensure the enclosure is weatherproof from extreme temperatures, ranging from 356°F to 464°F **Beck**. These are the melting points of the wires used in our circuits, which could lead to disconnections and ultimately circuit failure. The goal is also to protect the parts that make

up the pendulum and circuits from being exposed to seawater. Seawater will corrode stainless steel and circuits faster than non-salty water due to the increased amount of dissolved ions in seawater. Finally, another goal is to protect the components from birds and other marine life that may approach the enclosure. Ensuring the longevity and safety of the enclosed components while maintaining maximum operation is key.

Our team wants to ensure that the components of our device are protected from the outdoor weather, as specified in our project's aim, and from the movement of the electronic components inside the device. We want to ensure that the components are secure in the buoy and will not be damaged due to movement from the waves. In case internal components become loose, we want to take preventive measures to ensure the longevity of our parts. Finally, we want to ensure that the components are easily accessible to facilitate maintenance.

23.1 First Iteration

To begin, our team researched different materials for the enclosure, pendulum, and gears. Initially, high-power metal gears, bearings made of 301 stainless steel, springs made of stainless steel, and pendulums made of stainless steel or chromium were considered as high-quality options. These materials could withstand high temperatures, operate quietly while maintaining efficiency, and have non-corrosive properties. Our goal was to find materials that could perform well while withstanding high temperatures and resisting corrosion caused by seawater.

23.1.1 Logic

The temperature of the enclosure must be considered since the sun heats the water and reflects off it, raising the temperature of the surroundings and consequently heating the enclosure. Our pendulum, made of stainless steel, can absorb large amounts of heat. Stainless steel can withstand temperatures up to 1900°F **Chemseal**. A high operating temperature for stainless steel ensures that the surroundings of the pendulum stay relatively cool while the pendulum absorbs the heat. Additionally, a loud design will attract and disturb marine life in the surrounding area. Loud noises, also known as noise pollution, prevent marine life, such as whales, from communicating with each other. As a result, this affects their ability to reproduce, hunt, navigate, and avoid predators. According to the U.S. National Oceanic and Atmospheric Administration, noise levels above 160 dB will disrupt marine life. 160 dB is the noise level of a jet engine. Our device makes minimal noise compared to a jet engine, so our team assumes our device will not disturb marine life. Finally, since seawater is salty, our design is subject to corrosion faster than in freshwater. Non-corrosive properties of stainless steel and acrylic are used to prevent corrosion due to seawater. Our team's solution is to insert a rubber sheet in the middle of our sphere, preventing water from affecting the electronics and pendulum while also reducing noise.

23.2 Second Iteration

Our team created an initial design that allowed for compartments for each component, as shown in Figure 34(a). For example, the electronics would be stored at the top, the pendulum in the middle, and a small air conditioning unit at the bottom. Each compartment could be connected by a hinge on the left side, or possibly the components could be screwed together like a lid on a jar.

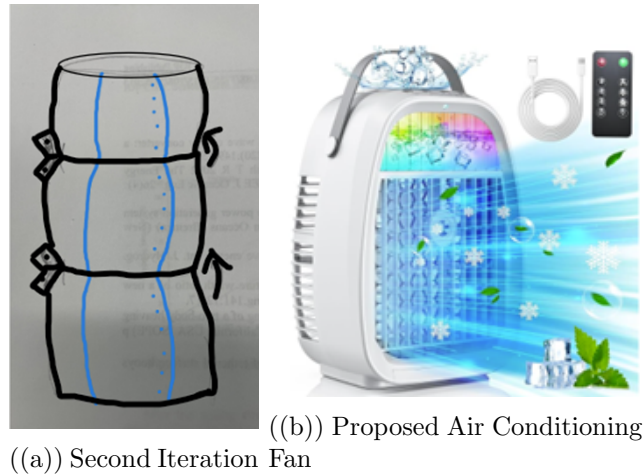

Figure 34: Second Iteration Design

23.2.1 Logic

The goal was to ensure that the pieces could be easily accessible without dismantling the entire design. The idea was to facilitate maintenance. This is why the electronics were to be stored at the top, allowing for easy replacement of these parts, as we anticipated this component would have the most issues. The small air conditioning unit or computer fan at the bottom would allow for air flow throughout the design, ensuring the enclosures stay relatively cool. Our concern was with the sun heating up the enclosure to high temperatures, as well as the electronics heating up the air inside. These factors could lead to faulty connections or malfunctions from the electrical and mechanical parts.

23.2.2 Challenges and Improvements

One challenge was how this design could be made in real life. Our team was unsure how the device would be easily accessible while maintaining a waterproof design. If each compartment is connected using a hinge, then it would be hard to keep the design waterproof. If the compartments are attached using a screw-on method, then the wiring of the electronic compartment to other compartments would not be possible with a floor separating each compartment.

23.3 Third Iteration

The team wanted to identify the sources of heat and solutions to mitigate it. Heat was identified as being produced from the motion of the pendulum, the material of the pendulum, the electrical circuit, and the ion battery. These elements were found to produce negligible amounts of heat; however, solutions were presented for preventative measures. If our team had more time, we would set up an experiment to measure how much heat the stainless steel would emit using our testing tank and a heat lamp to simulate the sun. Solutions were to use a 15-30 cubic feet per minute fan to circulate air or add a heat sink to the circuit to reduce the amount of heat added to the system. A heat sink, also known as a passive heat exchange, transfers heat to a fluid medium which dissipates the heat generated by the circuit. The team also identified that the color of the exterior needs to meet certain constraints. The design needs to avoid bright fluorescent or contrasting colors, dark blue, or black. Avoiding these colors will ensure that marine life and birds will leave the device alone. A white top will dissuade birds from interfering with the device. Additionally, spikes on

top of the buoy were proposed to dissuade larger marine life from biting or disturbing the device. Padding in the interior to ensure materials are not damaged in the event components become loose after being secured was also proposed. Our team considered using silicone walls to enclose the device, allowing air to pass through but not water. Adding foam padding on the internal walls was also considered to prevent water from soaking through or parts being damaged. This section is critical, as it contains practical problem-solving techniques:

1. Color selection on top and bottom.
2. Padding and using rubber sheets and silicone gel to avoid water penetration.

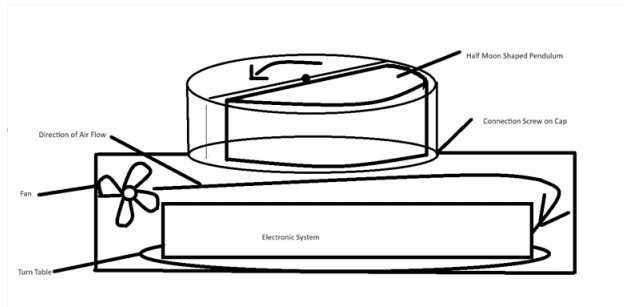

Figure 35: Last Iteration of Protection Design

23.4 Results

Our team decided to use a spherical design where the top is made of clear acrylic and the bottom sphere is stainless steel, which can be painted to our desired color. This design ensures that our team can easily access the electrical components if replacements are needed. The team used M8 bolts and nuts for ease of access, rubber sheets and washers between the layers to prevent water penetration, and sealed the seams with silicone. Stainless steel was used for the main components to prevent material degradation, such as corrosion caused by seawater. Finally, eye bolts were added to the top sphere to allow easy attachment to boats, another measure taken for ease of maintenance.

According to the Worldstainless association 36, depending on how much scrap the stainless steel is made of, CO2 emissions per ton of stainless steel can range from 2 to 7 tons **Worldstainless**.

CO2 Emissions

Scrap mix	CO ₂ emissions per ton of stainless steel
85% scrap	2.08
75% scrap	2.42
50% scrap	3.28
30% scrap	6.82

Figure 36: CO2 Emission Chart from Worldstainless

Our team estimates that our device comprises at most 47 pounds of steel, including a 5 kg pendulum, 2 kg shaft, and 39 kg hemisphere, accounting for the scrap produced when manufacturing our device. To safely estimate, we assume 10 CO₂ emissions per ton for our stainless steel, multiplied by 90, for a total of 900 CO₂ emissions or 3480 cubic feet of gas. This is an overestimation of how much CO₂ emissions are produced from our device, which is less than if our device produced CO₂ emissions. Since our device produces and stores energy generated from wave motion, our renewable energy device is a better alternative to non-renewable energy machines. Compared to other alternatives, such as solar panels that produce around 50 grams or 0.11 pounds of CO₂ in manufacturing one panel, our machine produces a significant amount of CO₂ emissions in manufacturing our device. However, in the long term, our device can last up to 50 years with the use of stainless steel, while solar panels need to be replaced every 20-30 years. Given more time, our team would set up a test to simulate how our device would compare to other renewable energy sources.

24 Mooring Line Design

Mathematical models for mooring systems have been developed to predict the hydrostatic equilibrium position and response to environmentally induced loads. The mathematical modeling approach for wave energy converter (WEC) mooring systems covers coordinate systems, system parameters, variables, environmental inputs, physical effects, resistance, interaction with the seafloor, snap loads, and bending/torsional effects.

24.1 Coordinate Systems and System Parameters

To effectively model the dynamics of wave energy converter (WEC) mooring systems, three main coordinate frames are required: the global frame (xyz) , the WEC frame $(x_w y_w z_w)$, and the curvilinear distance along the mooring line (s) . These frames, along with various vectors and angles, help define orientations and displacements. Key system parameters, such as mooring line geometry, material properties, and topology, determine the system's characteristics, including anchor

positions, buoy locations, mooring line lengths, and material properties. Understanding system behavior under load requires examining critical variables like length, strain, and tension. Environmental inputs, such as waves, currents, wind, and water depth variations, influence mooring line dynamics through static loading, low-frequency, and wave-frequency forces. Additionally, physical effects such as coupling to the WEC, buoyancy, seafloor interaction, snap loads, and compliance impact system behavior, necessitating comprehensive modeling. Mooring systems also exhibit resistive effects, including hydrodynamic drag, vortex-induced vibrations, internal line damping, and seabed interaction, which are crucial for accurate energy production estimation. Modeling seafloor interaction involves treating it as a distributed elastic support, providing resistance and energy dissipation. Sudden tension changes in slack mooring lines pose significant challenges and require careful consideration in modeling. While significant for some offshore structures, bending and torsional effects are negligible for WEC mooring systems, allowing for modeling simplification without sacrificing accuracy.

24.2 Mathematical Modeling of Mooring Systems

The mathematical modeling of mooring systems integrates various parameters, environmental inputs, and physical effects to accurately predict system behavior, which is crucial for the efficient design and operation of wave energy converters.

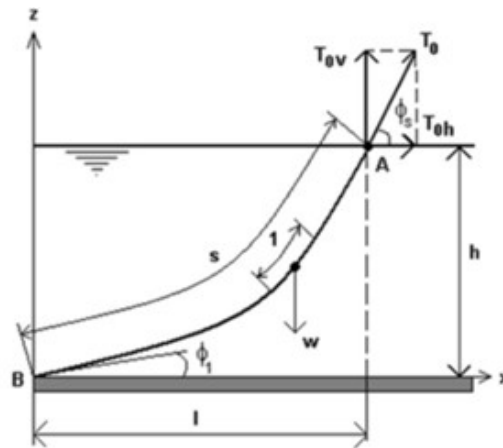

Figure 1. General mooring line geometry.

Figure 37: Genral Mooring Line Geometry

The tension in the mooring line is given by the formula $T = mg$, ignoring buoyant forces, wave forces, and wind forces:

$$T = (55 \text{ kg}) \cdot (9.8 \text{ m/s}^2) = 539 \text{ N} \quad (21)$$

24.3 Other Tension Factors

The tension T is related to the mooring line strain or deformation ϵ via a constitutive tension-strain relation with the general form:

$$T = f(\epsilon, s) \quad (22)$$

For the case of a linear stress-strain relationship:

$$T = EA\epsilon \quad (23)$$

The tension is a vector \mathbf{T} pointing in the direction of the tangent to the mooring line \mathbf{t}_m . The tension can be decomposed into its horizontal T_H and vertical T_V components. The tension at the top end connection point to the WEC is therefore decomposed into its horizontal and vertical components T_{Hw} and T_{Vw} respectively to determine the effects of the mooring forces on the WEC motion:

$$T_{Hw} = |\mathbf{T}| \cos(\theta_w) \quad (24)$$

$$T_{Vw} = |\mathbf{T}| \sin(\theta_w) \quad (25)$$

As more mooring lines are used, the tension in each line is reduced. In our WEC, we use three mooring lines, so the total tension in each mooring line is only one-third of the total tension.

25 Mooring Line Force

The mooring line force $F_{m.l.}$ can be derived from the elongation by Hook's law:

$$F_{m.l.} = k\Delta x \quad (26)$$

$$k = E \frac{A}{L_0} \quad (27)$$

where:

- E : Young's Modulus
- A : Cross-sectional Area
- L_0 : Original length of mooring line

Our calculations indicate that roughly 2000 N of force acts on the mooring lines in total, which is approximately 667 N per line.

25.1 Reducing Peak Load on the Mooring Line

According to a study by Davidson and Ringwood **davidson'ringwood**, the UoE tether can significantly reduce peak load on the mooring line under extreme wave conditions. The reduction amplitudes are up to 31% and 67% compared to Nylon and Chain cases, respectively. Therefore, the UoE tether is a promising solution for tension reduction and device stabilization. The UoE tether is compatible with different mooring configurations. Furthermore, if the WEC installation requirements demand different design criteria, the stiffness characteristics of the UoE tether can be modified to achieve softer or stiffer characteristics by changing the properties of the inner core material or the fiber strand lay angle.

Build and Test Challenge

26 Introduction to the Build and Test Challenge

This section details the design, fabrication, testing, and analysis of a horizontal pendulum-based wave energy converter (HP-WEC) developed as part of the Marine Energy Collegiate Competition (MECC). The project aimed to create a sustainable and cost-effective device for marine energy production, leveraging strategic decisions like outsourcing heavy or large components from China to reduce costs while maintaining quality.

26.1 Design Process and Material Selection

To prevent rust and ensure durability, stainless steel was chosen for key components; namely the large lower hemisphere, essential for the wave interaction. Most parts were manufactured with affordable materials from China. The hemisphere, with a diameter of 70 cm, had a metal plate welded towards its bottom to act as a supporting structure to the ball bearing carrying the steel shaft and steel pendulum 39. Figure 38 shows the detailed SolidWorks design. The welded plate has 4 threaded holes for plate fixation.

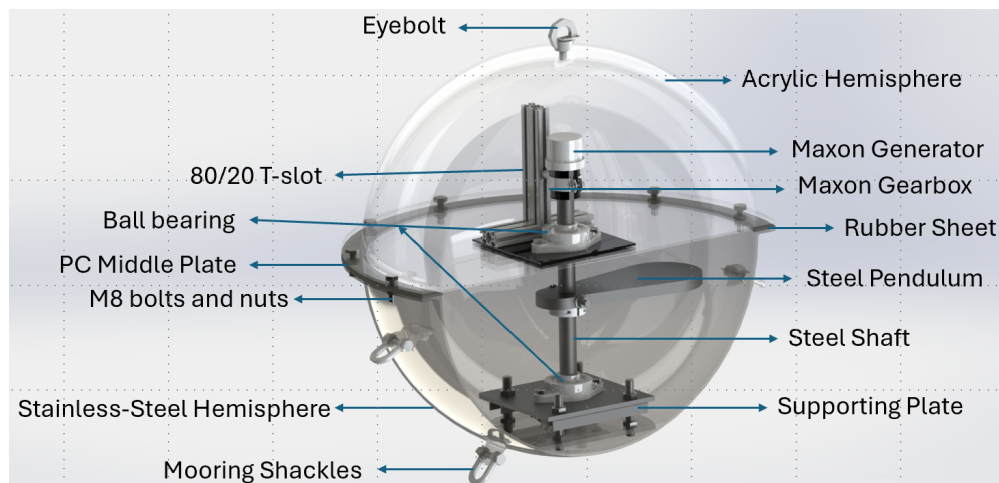

Figure 38: SolidWorks Design of the Pendulum Based Wave Energy Converter



Figure 39: Actual Fabricated Pendulum and Shaft

26.2 Sealing and Environmental Considerations

The design incorporated a PC sheet fastened to the hemisphere using M8 bolts and nuts, ensuring water resistance and environmental durability. Rubber sheets were placed between layers for water sealing, while an acrylic hemisphere protected the device from external elements 40.



Figure 40: Actual Fabricated Device with Rubber Gasket for Water Sealing

26.3 Assembly Considerations

The pendulum-based energy converter required easy access for maintenance and security measures, with clear surfaces allowing visual monitoring of rotating parts 41. Proper alignment was achieved using a bearing on top of the PC plate.

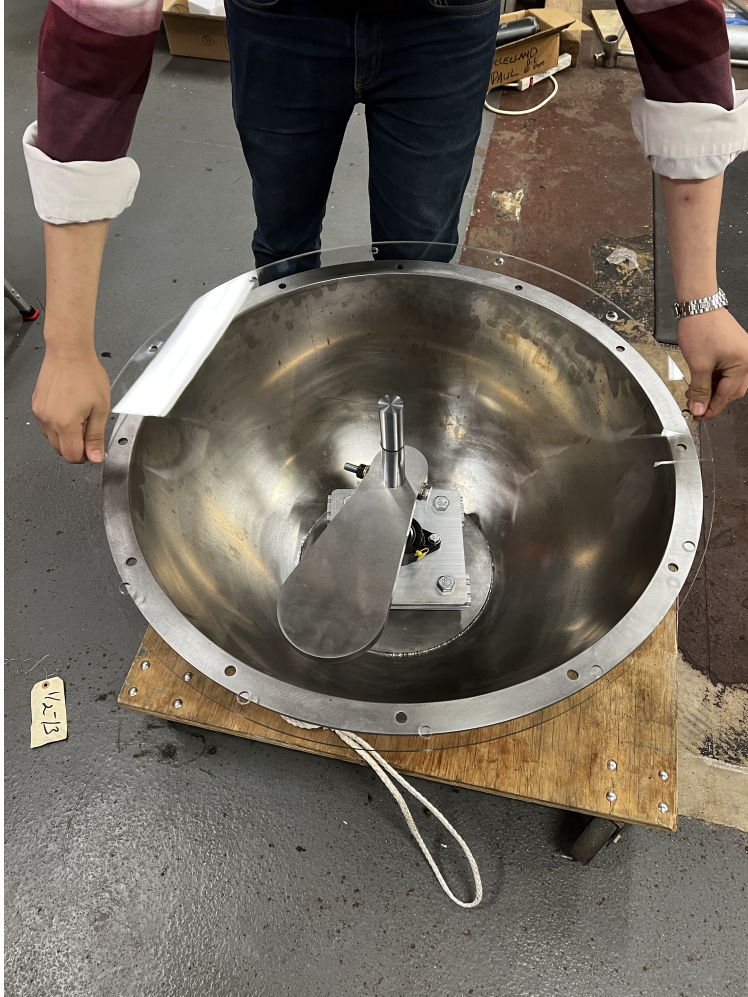

Figure 41: Attaching the Clear PC Plate on The Lower Hull

27 Prototype Fabrication

27.1 Outsourcing and Manufacturing

Strategic outsourcing to China helped in manufacturing the large hemisphere affordably 42, with careful planning for tooling time. Smaller components, sourced from McMaster, were included within budget based on specifications outlined in the business report.

27.2 Component Testing

The components underwent dry tests and calibration before assembly, ensuring functionality and compatibility. Sensors, including temperature and turbidity sensors, were tested individually before integration.

27.2.1 Calibration

Temperature sensors often require calibration. The graph in Figure 43 shows our testing for calibration, with a high of 101.44°C in boiling water and a low of 0.44°C in ice water. In our code, we



Figure 42: Lower Hull Delivered Polished and Ready for Assembly by DHL

subtracted 1.44°C from the reading for accuracy.

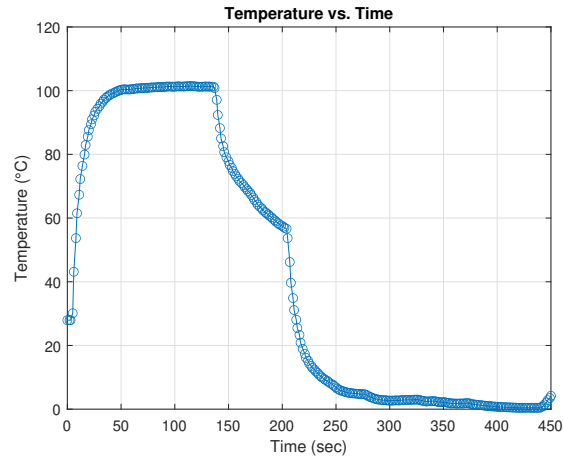

Figure 43: Temperature Sensor Graph

27.3 Experimental Data Collection

27.3.1 Initial Testing

We conducted three tests: clear water at room temperature, salty water, and warm water. We expected the clear and salty water temperatures to be around 20°C and the warm water above 40°C. We also predicted clear water and warm water to have similar clarity, while salty water would be less clear.

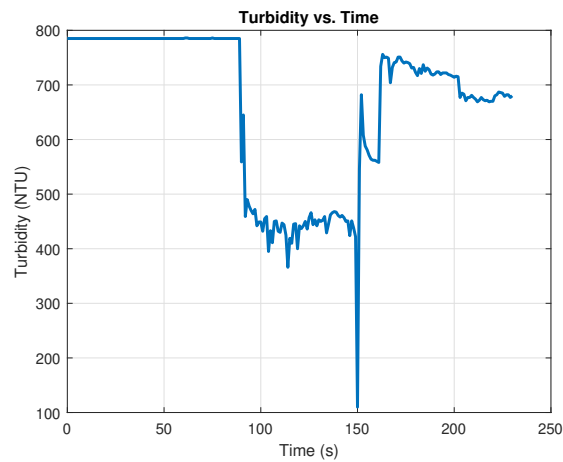

Figure 44: Experimental Data for Turbidity Calibration

The temperature probe measured around 18°C in clear water, dropping slightly more in salty water. In warm water, it increased significantly, reaching a maximum of 52.1°C. The turbidity sensor first measured 745 (clear water), dropped significantly in salty water, then increased in warm water.

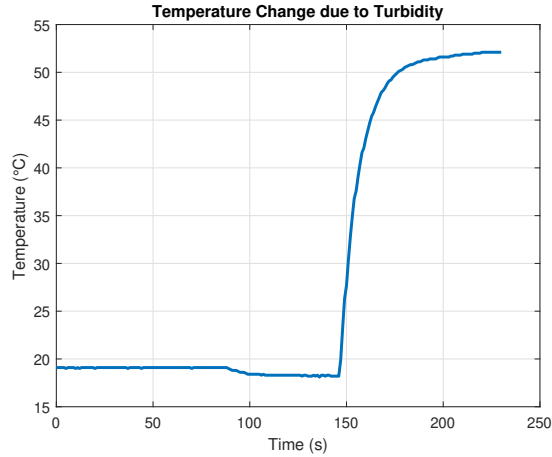

Figure 45: Temperature Change Due To Turbidity

28 Battery Discharge Graphs

28.1 Simulated Discharge

Before testing the lithium battery's discharge rate, we modeled the expected rate to verify performance. Figure 46 shows our predictions.

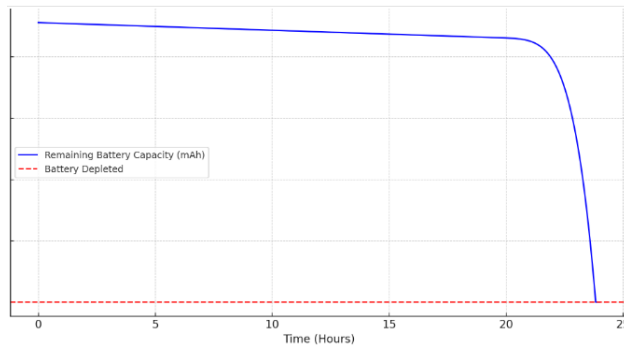

Figure 46: Simulated Discharge Graph of Lithium Battery

28.2 Observed Discharge

Figure 47 shows our observed discharge graph. The battery depleted at 24.5 hours, close to our predicted 24 hours, indicating accurate calculations. The graph has four stages: initial drop, mid-section, sharp decline, and depleted battery 47.

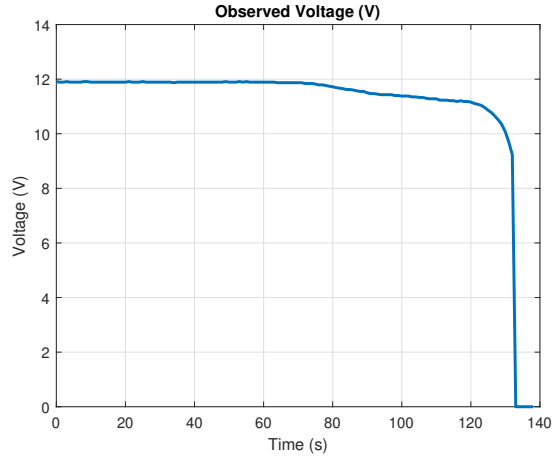

Figure 47: Observed Discharge Graph of Lithium Battery

29 Energy Production

We tested two different generators to harvest the rotational energy of our pendulum-based wave energy converter. The first generator we tested is a DC generator, while our second generator is bi-directional, using a high gearbox ratio, and generating AC power.

We tested the maximum voltage production of each generator and their relative ability to maintain a stable output.

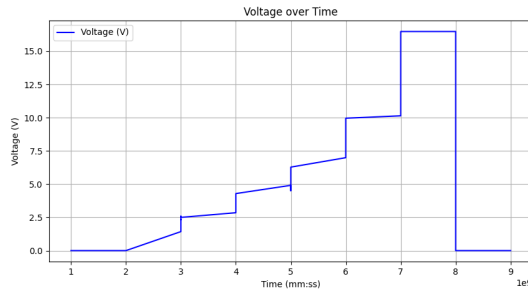

Figure 48: DC Generator Output

The graph above (Fig. 48) depicts the DC generator energy production, with time in units of tens of seconds. The DC generator reached a maximum voltage of 16 V, with stable and incremental jumps in voltage correlated with the RPM of the rotating shaft.



Figure 49: AC Generator Testing

To rotate the generator's shaft, a drill was employed, supplemented with various adapter pieces to ensure a compatible connection (Fig. 50). The DC motor achieved 16 V at 1500 RPM; however, it was incapable of producing any voltage beyond 16.48 V. It is likely a lower RPM is sufficient to produce this voltage.

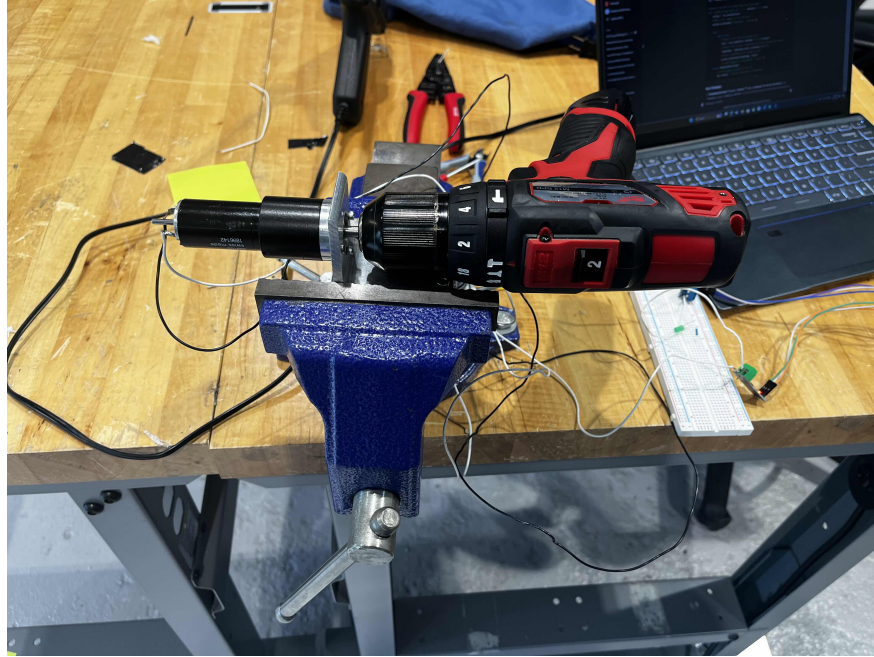

Figure 50: DC Generator Testing

When testing the maximum voltage production of the AC generator, we found that the voltage production exceeded that of the voltage sensor we were utilizing. Thus, we used a voltmeter to measure the absolute maximum voltage, which was observed to be 54.5 V at 1500 RPM (Fig. 49).

As the AC generator was capable of producing a higher voltage and featured an internal gearbox, we selected the AC generator for future implementation.



Figure 51: AC Generator and Pendulum Device

Above (Fig. 51) is our current setup, with the generator mounted vertically on the shaft of the pendulum. As our devices rely on DC power, we first include a small rectifier circuit to convert the AC to DC power.

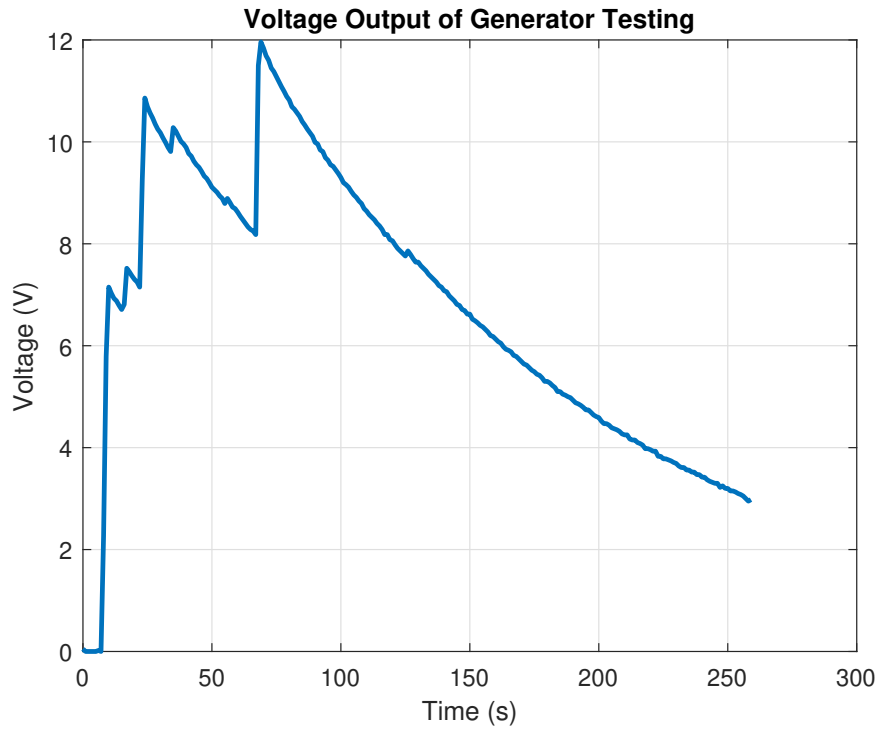

Figure 52: Experimental Energy Production

When we tested the experimental energy production of the pendulum-based wave energy converter, we obtained the graph shown in Fig. 52. In addition to the rectifier circuit, we added a capacitor to serve as a smoothing filter to lessen the impact of immediate changes in voltages.

29.1 Assembly

Assembly of the device occurred at Stevens Institute of Technology, where parts fabricated in the machine shop were integrated with outsourced components. Two Maxon generators were tested, and one of which was connected to the pendulum via a Maxon gearbox, successfully powered the onboard sensors (temperature and turbidity), and an IMU (Inertial Measurement Unit) for 6-degree-of-freedom (DOF) motion tracking.



Figure 53: Pendulum Drilling at Steven's Machine Shop

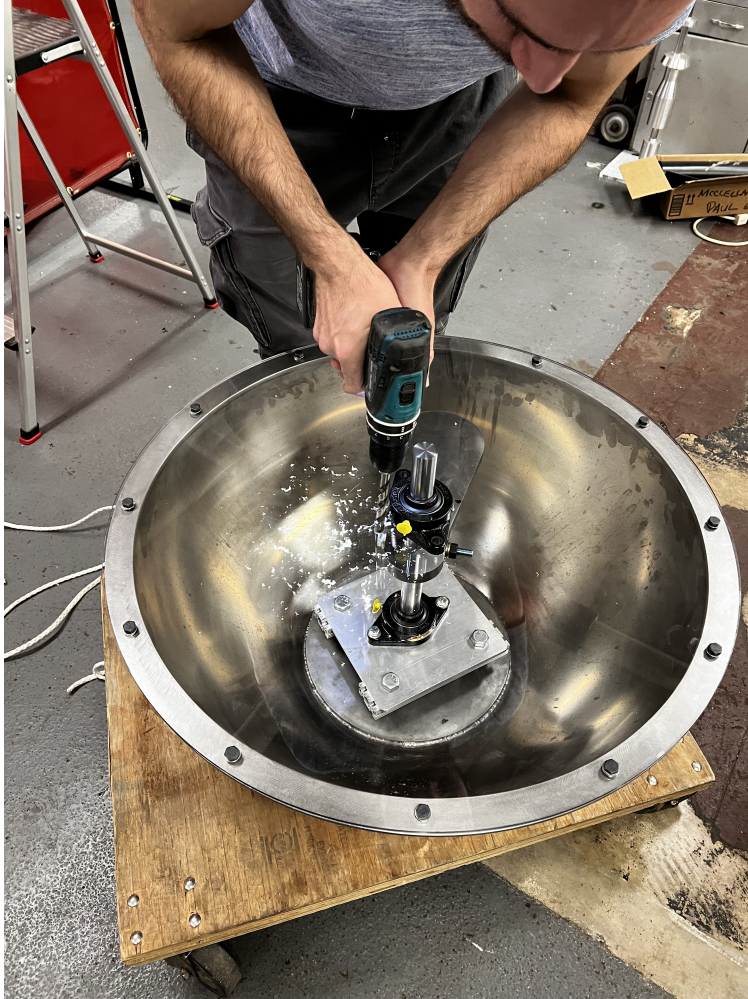

Figure 54: PC Drilling for Fixation and Wiring

30 Testing

30.1 Adjustment of Physical Properties

During testing, adjustments were made to the mooring lines and the balance between weight and buoyancy 55, optimizing stability and functionality in the water. 40 lbs were added to adjust the device's draft, i.e. the water level for optimum performance. Shackles for mooring and lifting were symmetrically placed on the lower hull for easy handling. Three mooring lines attached at 120 degrees around the lower hull. Pretension was determined from mooring calculations.

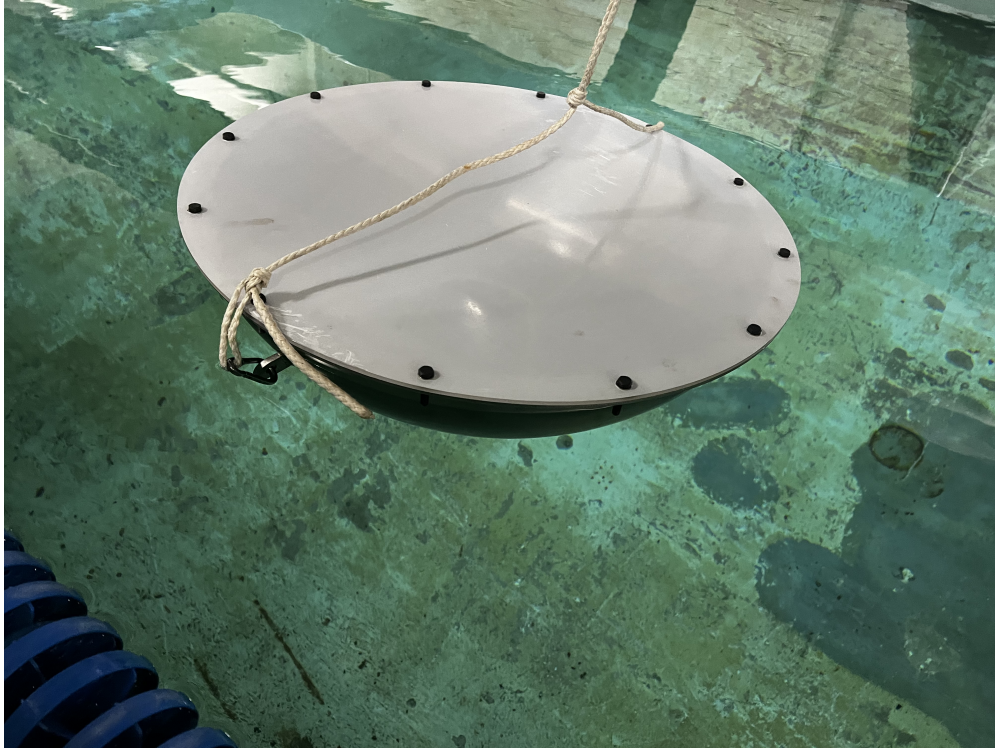

Figure 55: Initial Buoyancy Test to Adjust the Water Line

30.2 Choice of Mooring Line Material for Scaled Model Testing

The choice of mooring line material is crucial for WEC systems. After thorough analysis, Ultra-High Molecular Weight Polyethylene, specifically the UoE tether, emerges as the best option. Ultra-High Molecular Weight Polyethylene exhibits an impressive strength-to-weight ratio, surpassing steel. Its resistance to environmental degradation ensures reliability in harsh conditions. Low stretch and vibration damping enhance stability, which is crucial for energy conversion. Ultra-High Molecular Weight Polyethylene buoyancy aids handling and eliminates sinking concerns. Despite drawbacks like a low melting point and challenges with knot tying, its advantages make it the preferred material for WEC mooring systems.



Figure 56: Tether Mooring Lines for Easy Fixation and Deployment, anchored to 100 lbs on the bottom of the Wave Tank



Figure 57: UoE Tether Mooring Line [sciencedirect](https://www.sciencedirect.com)

30.3 Ease of Handling

Design considerations for handling included lubrication to enhance operational smoothness. Side Shackles were added for lifting the device. An eye bolt at the top indicated buoy anchoring as a side function, while also serving energy production and data gathering roles.

30.4 Testing in Davidson Lab

The model experiments were carried out in the Davidson Laboratory towing tank #3 58. The tank, measuring 313 feet long, 12 feet wide, and 6 feet deep, was ideal for testing the HP-WEC in regular and irregular waves 59. The tank's monorail carriage and integrated sensors provided accurate measurement and data acquisition, aiding in detailed analysis.



Figure 58: Layout of Davidson Lab Towing Tank

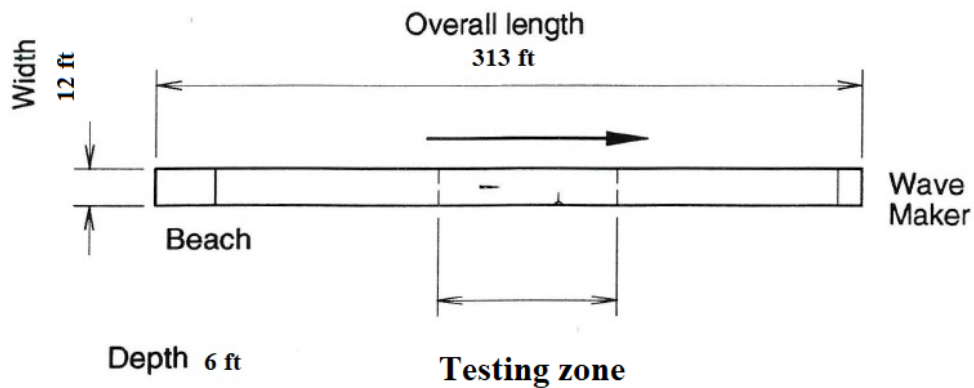

Figure 59: Layout of Davidson Lab Towing Tank

The pitch and heave of the buoy and the oscillations of the pendulum will be monitored throughout the test. Data will be collected from different sensors on the model and transmitted to the data acquisition system and then to the computer through overhead cables for analysis. This HP-WEC will be tested both in regular and irregular waves, at a range of frequencies. To reduce measurement due to instrument accuracy, A/D resolution, propagation errors, and mechanical or electrical

noises, all sensors will be calibrated, signals will be filtered with a 40 Hz filter and a low noise reduction for high frequency, and an optimal gain will be set for measuring instruments.

30.5 Sensors Data for Scaled Model

- The turbidity sensor used in this test is compatible with the Arduino system. It can detect the water quality by measuring the level of turbidity and transmit the recorded data. The working principle is to convert the current signal into the voltage output through the circuit. The lower the output voltage is, the higher the turbidity value. Its detection range is 0% - 3.5% (0-4550NTU), with an error range of $\pm 0.5\%$ F*S.
- The DS18B20 temperature probe sensor is submerged into the water tank to sense the temperature. Through a resistor on board, the sensor has an adapter module that is directly connected to a Microcontroller for water temperature monitoring. The main characteristics are: - Working voltage: 3.3 - 5 VDC, Output leads: yellow (DATA), red (VCC), black (GND) - Measuring range: -55 - 125 °C, Lead can only withstand a maximum temperature of 85 degrees.

The sea state was generated by an accurate dry behind wave makers technology. To test our model, the towing tank #3 facility is used. The basin features six flaps to generate regular waves and deep ocean irregular waves for testing our model. The movement of flap wavemakers is controlled by the software (wave generating software suite.) to defined sine or random sea state waves repeatable 128 s Pierson-Moskovitz spectrum and Jon-Swap technique. The technology of dry/wet-back flaps ensures that no back waves are generated during experiments for precision. This wave maker provides active absorption of reflected waves by the model and eliminates parasitic effects (built-in harmonics).

30.6 Sensors and Calibration

The main instruments of the tank and the sensors used for this test are listed in Tables 10 and 11. The device was tested in regular and irregular waves, with all sensors calibrated according to factory instructions. Safety precautions, including proper gear and stop mechanisms, were in place during the tests.

Instruments	Example of Channel number
IMU 6 AXIS components	1 to 6
Potentiometer	7
Heave Transducer	14
Pitch Transducer	15
Mooring load cell (LC3)	9
Multimeter	16
Wave Acoustic on Carriage	10
Wave Wire Upstream	Analog 5

Table 10: Davidson Laboratory Tank Details

Instruments	Measurement
Onboard Wave sensors (radar sensors/accelerometers/gyroscopes)	Wave Height and Period
Pressure transducer	Barometric Pressure
Acoustic Doppler Current Profiler	Currents
Pt-100 RTD (Resistance)	Temperature Recorder
Ultrasonic Wind Sensor	Wind Speed and Direction

Table 11: List of Sensors onboard the HPWEC

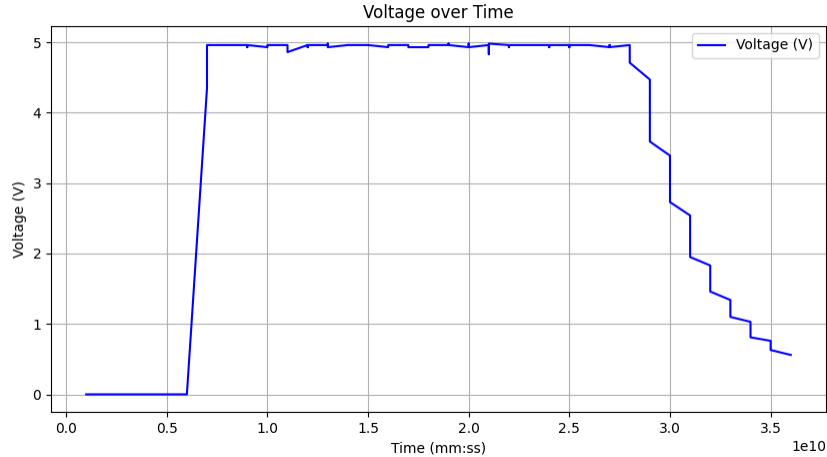

Figure 60: Generator Voltage Output -Dry Test-Low RPM (30)

30.7 Experimental Plan

The experimental plan included a wide range of wave amplitudes and frequencies (5 to 20 cm amplitude and 1.5-5 seconds wave periods), as well as irregular waves using the JONSWAP spectrum. Initial experiments have been conducted, and full experiments are set to complete within the coming week. More testing is currently undergoing at Davidson Lab to cover the wide range of the experimental plan.

30.8 Data Analysis and Results

We were experiencing issues with generating a constant expected voltage in order to power the charge controllers that will recharge the batteries being used. Our generator produces a varying voltage depending on the speed of the pendulum, utilizing a boost converter would solve allow us to generate higher voltages. However, we were able to cap the voltage at 5 v to prevent damage of other components. The following figure shows the voltage output for a low rpm pendulum rotation during a dry test 60. Unfortunately, the wave tank test are scheduled at the time of the report delivery. Thus results from the IMU sensor (motion of the hull) as well as wave elevations are scheduled and generator output will be available during the final event at Oregon.

31 Lessons Learnt

31.1 Challenges in Outsourcing

Outsourcing challenges included logistical issues and quality control concerns. These were mitigated through clear communication with suppliers and detailed planning. Although complications occurred and shipping took months, we finally managed to get all components and assemble the device in time.

31.2 Insights from Environmental Considerations

Environmental impact considerations shaped design choices, such as minimizing harm to marine life through color and spike design, as illustrated in section 11, design considerations. Sealing options and material selections were influenced by environmental durability needs.

31.3 Future Improvements

Future improvements include better component integration, reduced environmental impact, and enhanced operational efficiency. Logistical planning for outsourcing and improved sensor calibration processes are also recommended.

31.4 Project Recap and Future Considerations

The project demonstrated strategic decisions to enhance sustainability and operational effectiveness in a pendulum based wave energy converter that is easily scaled to fit the application. Potential applications include marine research, environmental monitoring, and renewable energy generation, contributing valuable data for environmental studies and energy production. Optimization to the energy production, lifetime operation and maintenance is necessary for improved efficiency.

32 Personal Statements

Cole Spitzner: After a year of involvement with the Stevens MECC team, as many webinars and monthly calls as I could fit into my schedule, keeping up to date through informative Tethys blasts from PNNL, and a bit of my own research into the field, my interest and awareness of the marine energy industry has grown exponentially. It even influenced my internship search and helped me to secure an engineering intern role at the American Bureau of Shipping this summer. I am very grateful for joining the MECC team at Stevens and for the entire system of MECC operations including the webinars, open office hours, and more. I am super excited to present our work and network with marine energy professionals and fellow interested students at the end of year event at OREC 2024.

Maribeth Suganuma: From my involvement with the MECC team at my university, I have learned a great deal about renewable energy and marine devices. Researching and learning about other wave power devices has opened my eyes to the amount of time and money that is put into these types of devices. This experience has helped me understand all the work that is put into a research project and I hope to contribute my experience from the project to the team next year. Additionally, I hope to use my experience in the future when researching and designing my own renewable energy vehicle that I hope to make in the future.

Sarah Nayema: I have always been interested in ocean engineering, but growing up in largely metropolitan and heavily polluted natural water sources has limited my exposure to the potential of the blue economy in terms of commerce, industrialization, and applications for research. Involvement with the MECC team has allowed me to delve into the major scientific breakthroughs and innovative designs that have taken advantage of water's unique conditions to utilize it as an alternate energy source. Taking inspiration from existing research projects and products already engineered for the purposes of data collection, I was able to learn and experiment with MATLAB, Arduino, and various autonomous data collectors to configure a self-powering system. This project has given me the opportunity to see a product through from design to implementation and sparked an interest into designing with the intention of supplementing natural bodies of water to mitigate some of the environmental harm done to them. I am incredibly grateful to have the MECC program as an outlet for my creative interests and for introducing me to viable new career options.

Ahmed Shah: My involvement in this innovative project allowed me to leverage and expand my technical skills in several key areas. I was primarily responsible for integrating Arduino microcontrollers, which served as the brains of our device. This required not only programming the units but also ensuring they communicated effectively with other components. Additionally, I designed and assembled the electronic circuits that connected energy converters with the Arduinos, ensuring seamless energy flow and system stability. The hands-on experience with voltage converters highlighted the importance of precise voltage regulation in marine electronics. These converters were crucial in adapting wave energy into usable electrical outputs to reliably power our sensors. This project sharpened my technical abilities and deepened my appreciation for interdisciplinary collaboration in renewable energy technologies. Working in a dynamic environment taught me to be adaptable and innovative, skills I look forward to using in future endeavors. I'm grateful for the opportunity to contribute to this groundbreaking project and excited about its potential impact on marine conservation.

Amira: During my time on this project, I've gained invaluable experience in renewable energy and data analytics. I've learned the intricate processes involved in developing a pendulum-based wave energy converter, deepening my understanding of sustainable energy solutions and oceanographic data collection. This experience broadened my horizons, showing me the real-world applications of clean energy technologies and their potential environmental and social impact. The

importance of teamwork became clear as we navigated the project's complexities. Our supportive team enabled me to write a comprehensive report, reflecting our collective hard work and dedication. By leveraging each team member's expertise, we developed a holistic approach that aligns with market trends and offers a vision for a sustainable future.

Ahmed Shalaby: As a team leader, I've gained precious insights into project management and time management. I've developed strong relationships with my teammates as we worked together to achieve something great. I would like to express my gratitude to the MECC community for providing us with this amazing opportunity to learn, gain experience, and nurture our minds. Moreover, by providing clean, renewable, and sustainable solutions for the blue environment, we are contributing to the well-being of our planet. This experience has also been a significant step towards technological development and personal and community advancement.

33 References

- 1 Business and design report submitted by Stevens Institute of Technology 2023.
- 2 Water Power Technologies Office. U.S. Department of Energy, <https://www.energy.gov/eere/water/water-power-technologies-office>.
- 3 International Energy Agency, <https://www.iea.org/>.
- 4 National Renewable Energy Laboratory, <https://www.nrel.gov/>.
- 5 BloombergNEF. Bloomberg Finance L.P., <https://about.bnef.com/>.
- 6 Wood Mackenzie, <https://www.woodmac.com/>.
- 7 Resources for the Future, <https://www.rff.org/>.
- 8 Ocean Conservancy, <https://oceanconservancy.org/>.
- 9 "Capital Cost Breakdown of Wave Energy Converters." ResearchGate Alexander Hugues-Dit-Ciles 26 Sept. 2015, https://www.researchgate.net/figure/Capital-cost-breakdown-of-wave-energy-fig4_305126646.
- 10 Xiaoqiang Jiang, Hongda Shi, Feifei Cao, Zhilei Zhao, Ming Li, Zhen Chen (2023). System analysis and experimental investigation of a pendulum-based wave energy converter. Ocean Engineering.
- 11 US Department of Commerce N. O. and A. A. (1996 November 8). NDBC station page. National Data Buoy Center, https://www.ndbc.noaa.gov/station_page.php?station=44091.
- 12 US Department of Commerce N. O. and A. A. (n.d.). National Data Buoy Center, <https://www.ndbc.noaa.gov/faq/measdes.shtml>.
- 13 textscan matlab, https://www.youtube.com/watch?v=0MtpTWKIKrU&ab_channel=PainlessProgramming.
- 14 Reading and Plotting Data from a Text File in MATLAB, https://www.youtube.com/watch?v=-g3yIUws-rI&ab_channel=drselim.
- 15 Wave Energy Calculator, <https://greener4life.com/Wave-Energy-Calculator>.
- 16 How to plot multiple graph in MATLAB — Subplot in MATLAB — Hold on in MATLAB — MATLAB TUTORIALS, https://www.youtube.com/watch?v=XvVu4wLlK3A&t=1s&ab_channel=LearningVibes.
- 17 Team E. (2023 March 30). Understanding Sea State: A Comprehensive Guide. OUCO, <https://ouco-industry.com/understanding-sea-state-a-comprehensive-guide/>.
- 18 CB-75 Data Buoy, <https://www.nexsens.com/products/data-buoys/cb-75-data-buoy>.
- 19 NexSens CB-75 Data Buoy, <https://miljovann.com/products/nexsens-cb-75-data-buoy>.
- 20 US Department of Commerce N. O. and A. A. (n.d.-b). NDBC Station Page, https://www.ndbc.noaa.gov/station_page.php?station=46050.
- 21 <https://spotters.sofarocan.com/historical/SPOT-30903C?user-filter=1531>.

- 22 https://www.ndbc.noaa.gov/station_history.php?station=46050.
- 23 https://www.ndbc.noaa.gov/station_page.php?station=46050.
- 24 Beck Anton. “Battery Cell Thermal Runaway: What Does It Mean and How to Avoid It.” Epec’s Blog, <https://blog.epectec.com/battery-cell-thermal-runaway-what-does-it-mean-and-how-to-avoid-it/>
- 25 Dpadmin. “How Salt Water Corrosion Is Devaluing Your Property & How to Stop It.” Vinyl Fence Wholesaler 29 Mar. 2023, <https://www.vinylfenceanddeck.com/our-blog/how-salt-water-corrosion-is-devaluing-your-property-and-how-to-stop-it>.
- 26 EMS Solutions. “Can High Temperature Damage A PCB?” EMS Solutions, <https://www.myemssolutions.com/can-high-temperature-damage-a-pcb>.
- 27 “Stainless Steels and CO2: Industry Emissions and Related Data.” Worldstainless, <https://www.worldstainless.org/about-stainless/environment/stainless-steels-and-co2-industry-emissions>
- 28 “What Is the Max Operating Temperature for Stainless Steel?” Chemseal Inc., <https://www.chemsealinc.net/blog/what-is-the-max-operating-temperature-for-stainless-steel>.
- 29 Amazon.com: AI Portable Air Conditioners FanTYTAB Evaporative Mini Air Conditioner-Portable AC Air Cooler with 4 in 1 Humidifier Fan Conditioner 7 Colors Light 3 Speed AC Portable for Room Bedroom Office Desk: Home & Kitchen.
- 30 A Wave Power Device with Pendulum Based on Ocean Monitoring Buoy. Hui Chai et al 2018 IOP Conf. Ser.: Earth Environ. Sci. 108 052013 DOI 10.1088/1755-1315/108/5/052013
- 31 https://ir.library.oregonstate.edu/concern/graduate_thesis_or_dissertations/dn39x4011
- 32 Jia Mi, Qiaofeng Li, Mingyi Liu, Xiaofan Li, Lei Zuo, Design, modelling, and testing of a vibration energy harvester using a novel half-wave mechanical rectification, Applied Energy, Volume 279, 2020, 115726, ISSN 0306-2619, <https://doi.org/10.1016/j.apenergy.2020.115726>.