

Wave Powered Distillation

All-in-one design **collects wave energy** to generate heat to **accelerate the evaporation process**.

- **Moment arm driven by waves**
Powers the custom generator system to collect power at all times.
- **Evaporated water is collected**
The dome creates a natural greenhouse effect to collect the condensed vapors and direct them into the water reservoir.
- **Brine is captured in the system**
The salt-heavy water will collect in the bottom of the system to be retrieved at-will.
- **Pressurized system moves water**
The motion of the moment arm applies pressure to the water reservoir to move the water to shore..
- **Closed Loop Discharge**
Gives total control to how the brine is discharged / utilized.

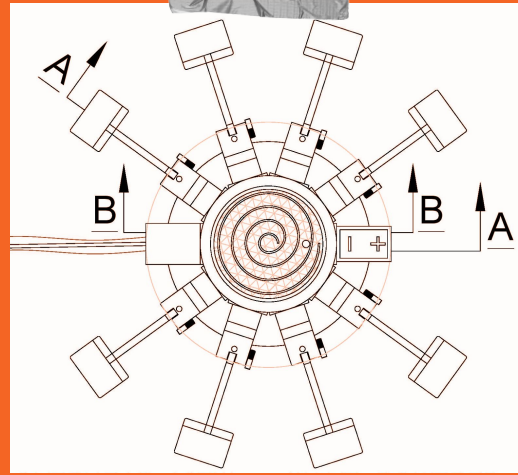

Wide-spread base **prevents the system from capsizing** in all wave conditions.

Top-Heavy design **amplifies production** by generating erratic movements that are captured by the moment arm.

SECTION A-A

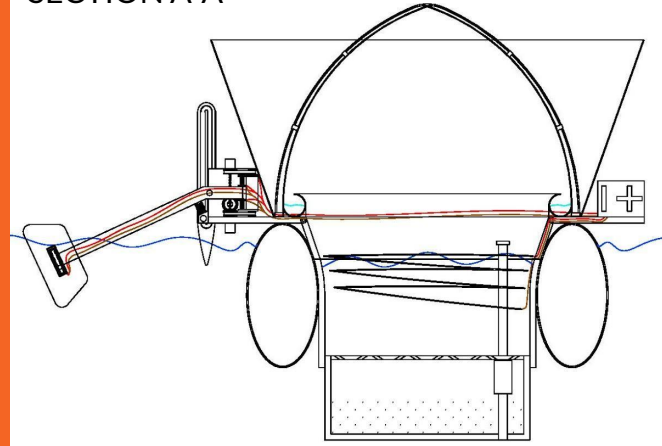

SECTION B-B

