

SHIPPING CONTAINER

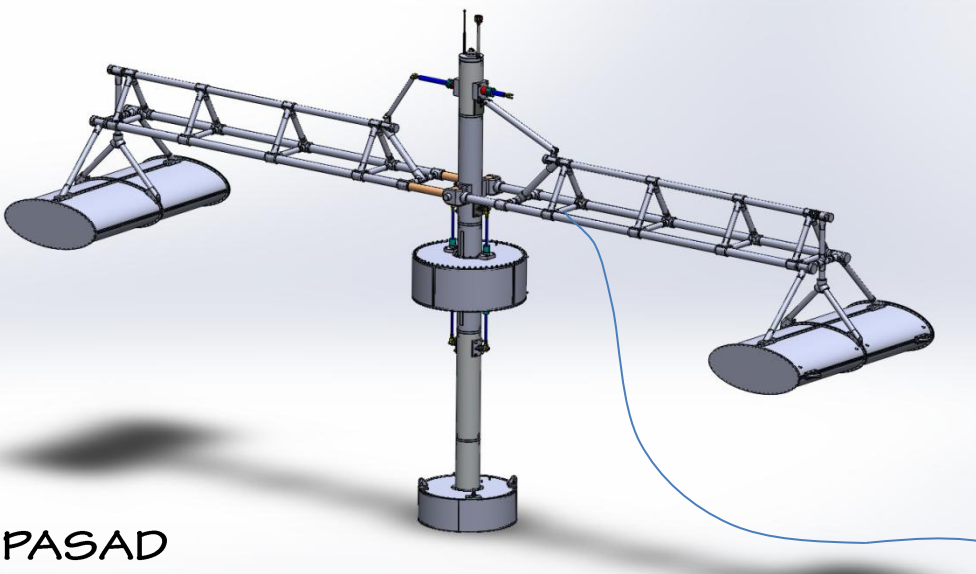

PASAD

- POINT ABSORBER
- SURFACE ATTENUATOR
- HYDRAULIC PISTONS FOR PRESSURE GENERATION
- ENERGY RECOVERY AND BATTARIES

INTERCONNECTING FLEX. HOSES BETWEEN PASAD AND DESALINATION SKID

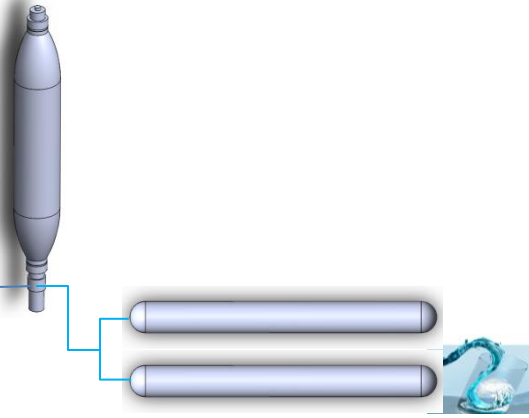

DESALINATION SKID

- PARALLEL RO ELEMENTS WITH BY-PASS VALVES
- ACCUMULATOR, VALVES, SENSORS
- QUICK COUPLING CONNECTION FOR HOSES
- ENERGY RECOVERY AND BATTARIES



**PASAD
CLEAN WATER FOR ALL**



Stage II DESIGN